

Outline of Full-Closed Control

What Is Full-Closed Control ?

In this full-closed control, you can make a position control by using a linear scale mounted externally which detects the machine position directly and feeds it back.. With this control, you can control without being affected by the positional variation due to the ball screw error or temperature and you can expect to achieve a very high precision positioning in sub-micron order.

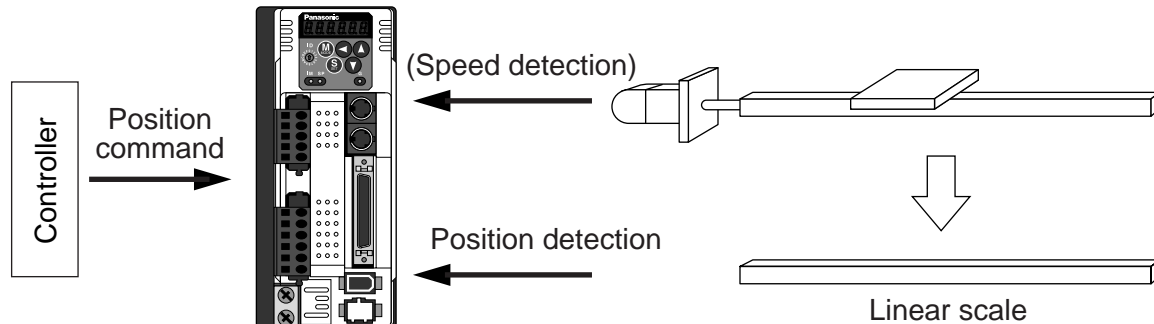

We recommend the linear scale division ratio of $\frac{1}{20} \cong$ Linear scale division ratio $\cong 20$

Cautions on Full-Closed Control

- (1) Enter the command pulses making the external scale as a reference.
If the command pulses do not match to the external scale pulses, use the command division/multiplication function (Pr48-4B) and setup so that the command pulses after division/multiplication is based on the external scale reference.
- (2) A4-series supports the linear scale of a communication type. Execute the initial setup of parameters per the following procedures, then write into EEPROM and turn on the power again before using this function.

<How to make an initial setup of parameters related to linear scale >

- 1) Turn on the power after checking the wiring.
- 2) Check the values (initial) feedback pulse sum and external scale feedback pulse sum with the front panel or with the setup support software, PANATERM .
- 3) Move the work and check the travel from the initial values of the above 2).
- 4) If the travel of the feedback sum and the external scale feedback pulse sum are reversed in positive and negative, set up the reversal of external scale direction (Pr7C) to 1.
- 5) Set up the external scale division ratio (Pr78-7A) using the formula below,

$$\begin{aligned} \text{External scale division ratio} &= \frac{\text{Total variation of external scale feedback pulse sum}}{\text{Total variation of feedback pulse sum}} \\ &= \frac{\text{Pr78} \times 2^{\text{Pr79}}}{\text{Pr7A}} \end{aligned}$$

* If the design value of the external scale division ratio is obtained, set up this value.

- 6) Set up appropriate value of hybrid deviation excess (Pr7B) in 16 pulse unit of the external scale resolution, in order to avoid the damage to the machine.

* A4-series driver calculates the difference between the encoder position and the linear scale position as hybrid deviation, and is used to prevent the machine runaway or damage in case of the linear scale breakdown or when the motor and the load is disconnected.

If the hybrid deviation excess range is too wide, detection of the breakdown or the disconnection will be delayed and error detection effect will be lost. If this is too narrow, it may detect the normal distortion between the motor and the machine under normal operation as an error.

* When the external scale division ration is not correct, hybrid deviation excess error (Err25) may occur especially when the work travels long distance, even though the linear scale and the motor position matches.

In this case, widen the hybrid deviation excess range by matching the external scale division ratio to the closest value.

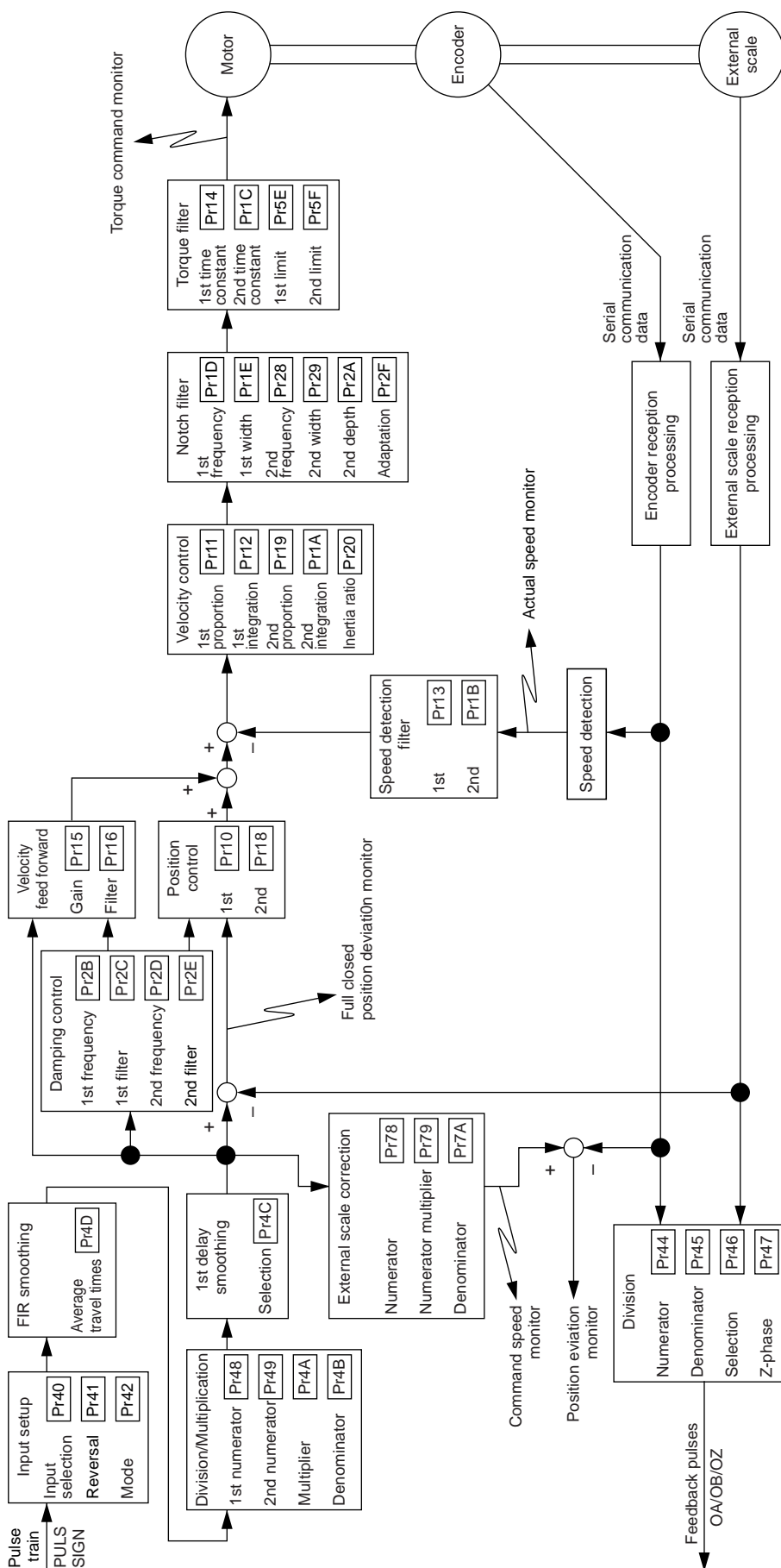

Wiring to the Connector, CN X5

Wiring Example to the Connector, X5

Wiring example of full-closed control mode

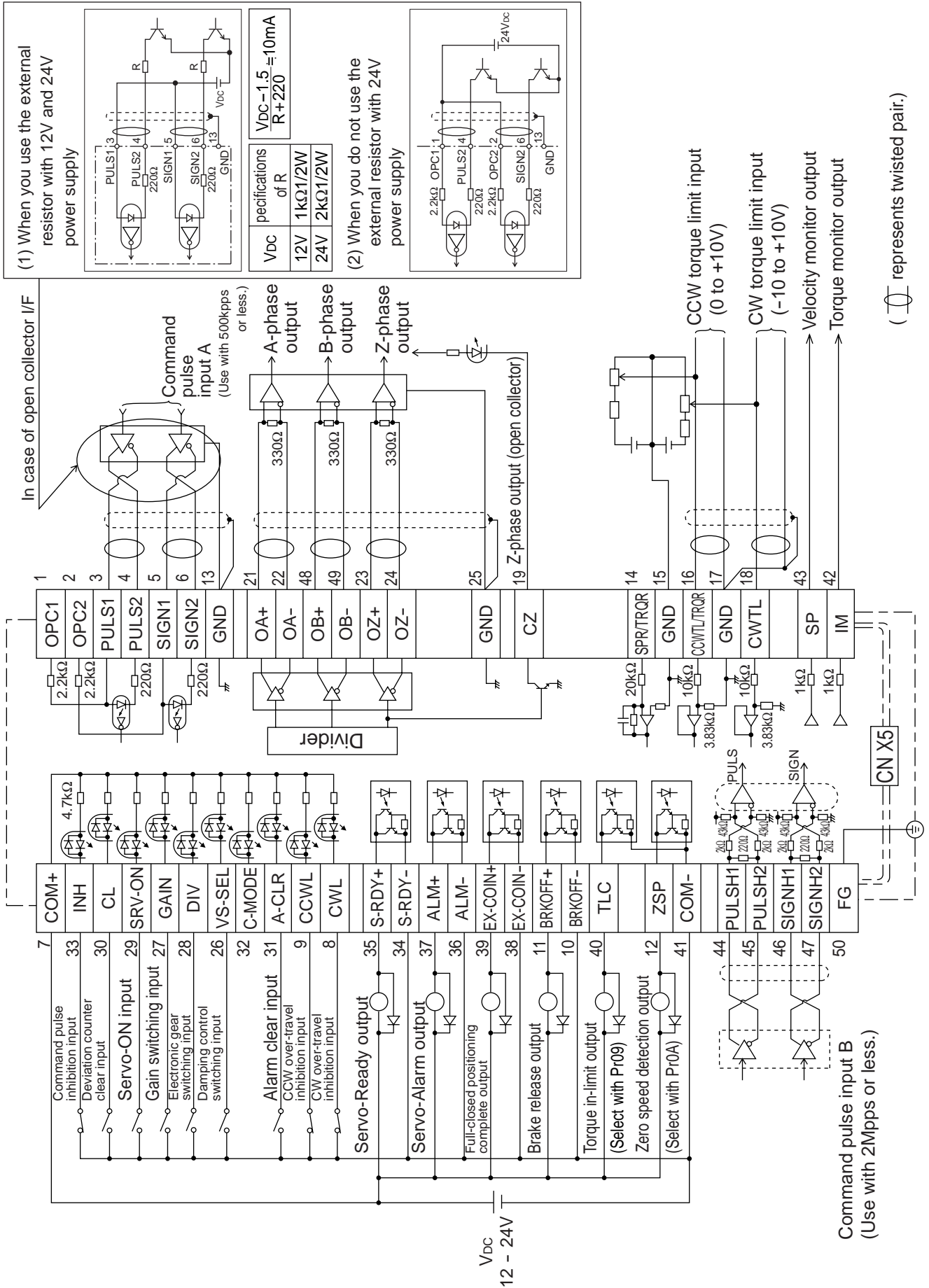

Interface Circuit

Input Circuit

SI Connection to sequence input signals

- Connect to contacts of switches and relays, or open collector output transistors.
- When you use contact inputs, use the switches and relays for micro current to avoid contact failure.
- Make the lower limit voltage of the power supply (12 – 24V) as 11.4V or more in order to secure the primary current for photo-couplers.

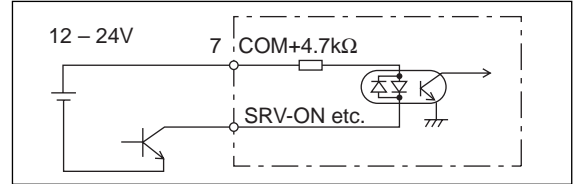
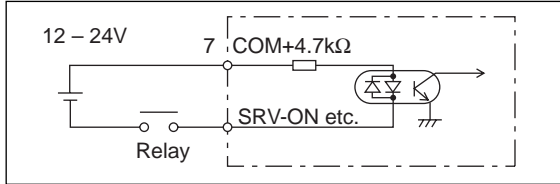

PI1 Connection to sequence input signals (Pulse train interface)

- (1) Line driver I/F (Input pulse frequency : – 500kpps)
 - This signal transmission method has better noise immunity. We recommend this to secure the signal transmission.
- (2) Open collector I/F (Input pulse frequency : – 200kpps)
 - The method which uses an external control signal power supply (V_{DC})
 - Current regulating resistor R corresponding to V_{DC} is required in this case.
 - Connect the specified resistor as below.

V _{DC}	Specifications
12V	1kΩ/1/2W
24V	2kΩ/1/2W

$$\frac{V_{DC}-1.5}{R+220} \approx 10\text{mA}$$

- (3) Open collector I/F (Input pulse frequency : – 200kpps)
 - Connecting diagram when a current regulating resistor is not used with 24V power supply.

represents twisted pair.

Max. input voltage : DC24V,
Rated current : 10mA

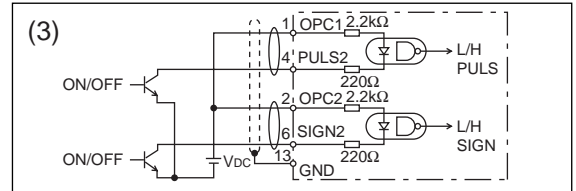
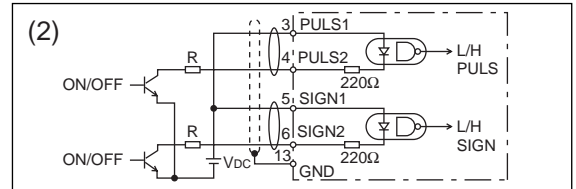
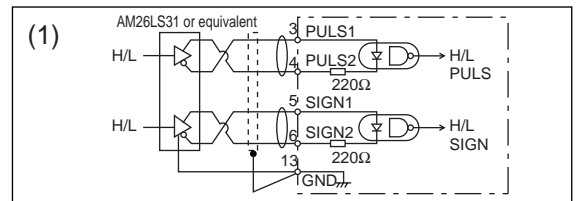

PI2 Connection to sequence input signals (Pulse train interface exclusive to line driver)

- Line driver I/F (Input pulse frequency : – 2Mkpps)
- This signal transmission method has better noise immunity. We recommend this to secure the signal transmission when line driver I/F is used.

represents twisted pair.

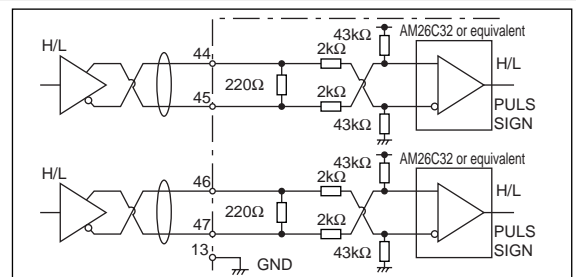

AI Analog command input

- The analog command input goes through 3 routes, SPR/TRQR (Pin-14), CCWTL (Pin-16) and CWTL (Pin-18).
- Max. permissible input voltage to each input is ±10V. For input impedance of each input, refer to the right Fig.
- When you compose a simple command circuit using variable resistor (VR) and resistor R, connect as the right Fig. shows. When the variable range of each input is made as –10V – +10V, use VR with 2kΩ, B-characteristics, 1/2W or larger, R with 200Ω, 1/2W or larger.
- A/D converter resolution of each command input is as follows.
 - (1) ADC1 : 16 bit (SPR/TRQR), (including 1bit for sign), ±10
 - (2) ADC2 : 10 bit (CCWTL, CWTL), 0 – 3.3V

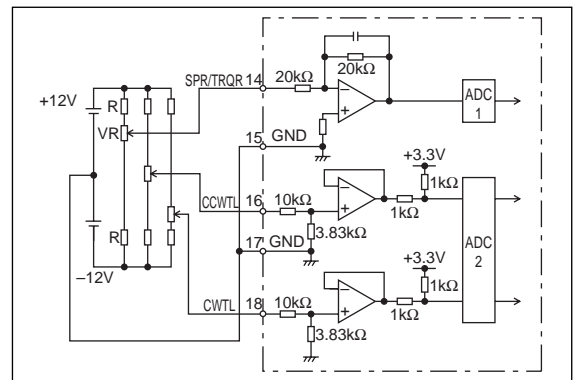

Wiring to the Connector, CN X5

Output Circuit

SO1 SO2 Sequence output circuit

- The output circuit is composed of open collector transistor outputs in the Darlington connection, and connect to relays or photo-couplers.
- There exists collector to emitter voltage, $V_{CE(SAT)}$ of approx. 1V at transistor-ON, due to the Darlington connection of the output or. Note that normal TTL IC cannot be directly connected since it does not meet V_{IL} .
- There are two types of output, one which emitter side of the output transistor is independent and is connectable individually, and the one which is common to - side of the control power supply (COM-).
- If a recommended primary current value of the photo-coupler is 10mA, decide the resistor value using the formula of the right Fig.

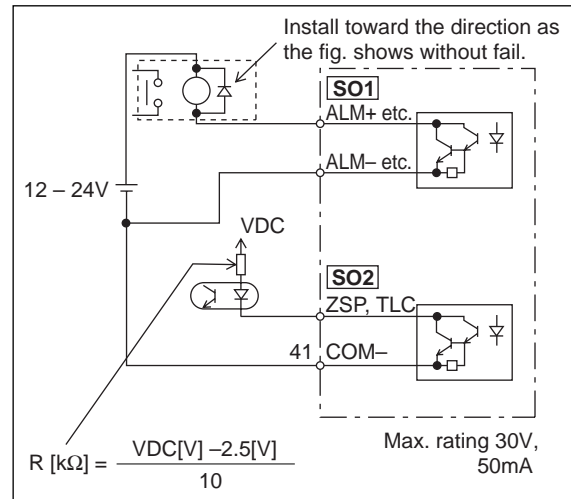

For the recommended primary current value, refer to the data sheet of apparatus or photo-coupler to be used.

SO1 Line driver (Differential output) output

- Feeds out the divided encoder outputs (A, B and Z-phase) in differential through each line driver.
- At the host side, receive these in line receiver. Install a terminal resistor (approx. 330Ω) between line receiver inputs without fail.
- These outputs are not insulated.

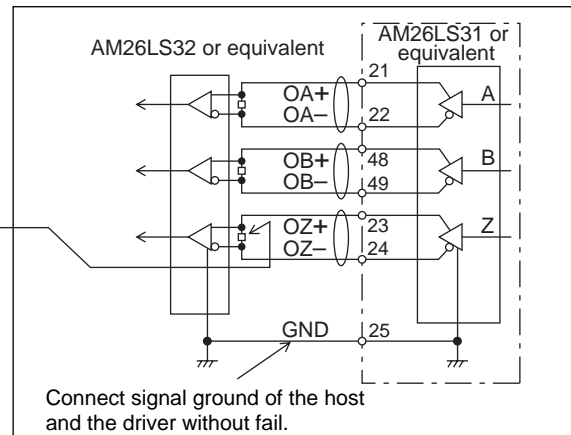

represents twisted pair.

SO2 Open collector output

- Feeds out the Z-phase signal among the encoder signals in open collector. This output is not insulated.
- Receive this output with high-speed photo couplers at the host side, since the pulse width of the Z-phase signal is narrow.

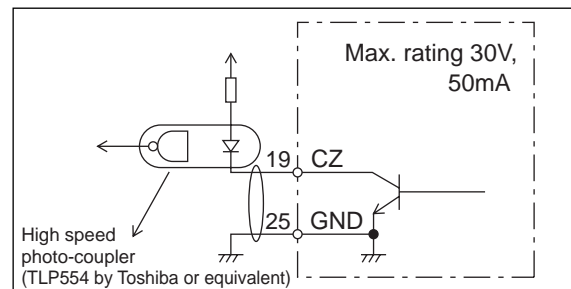

represents twisted pair.

AO Analog monitor output

- There are two outputs, the speed monitor signal output (SP) and the torque monitor signal output (IM)
- Output signal width is $\pm 10V$.
- The output impedance is $1k\Omega$. Pay an attention to the input impedance of the measuring instrument or the external circuit to be connected.

<Resolution>

(1) Speed monitor output (SP)

With a setup of 6V/3000r/min (Pr07=3), the resolution converted to speed is 8r/min/16mV.

(2) Torque monitor output (IM)

With a relation of 3V/rated torque (100%), the resolution converted to torque is 0.4%/12mV.

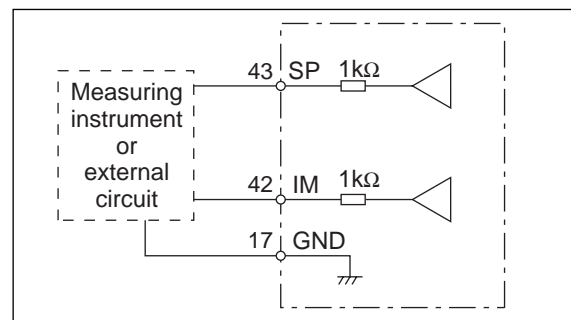

Input Signal and Pin No. of the Connector, CN X5

Input Signals (common) and Their Functions

Title of signal	Pin No.	Symbol	Function	I/F circuit																											
Power supply for control signal (+)	7	COM+	<ul style="list-style-type: none"> Connect + of the external DC power supply (12 to 24V). Use the power supply voltage of 12V ± 5% – 24V ± 5% 	–																											
Power supply for control signal (–)	41	COM–	<ul style="list-style-type: none"> Connect – of the external DC power supply (12 to 24V). The power capacity varies depending on a composition of I/O circuit. 0.5A or more is recommended. 	–																											
CW over-travel inhibit input	8	CWL	<ul style="list-style-type: none"> Use this input to inhibit a CW over-travel (CWL). Connect this so as to make the connection to COM– open when the moving portion of the machine over-travels the movable range toward CW. CWL input will be invalidated when you set up Pr04 (Setup of over-travel inhibit input) to 1.Default is "Invalid (1)". You can select the action when the CWL input is validated with the setup of up Pr66 (Sequence at over-travel inhibit). Default is "Emergency stop with dynamic brake".(Pr66=0) 	SI P.193																											
CCW over-travel inhibit input	9	CCWL	<ul style="list-style-type: none"> Use this input to inhibit a CCW over-travel (CCWL). Connect this so as to make the connection to COM– open when the moving portion of the machine over-travels the movable range toward CCW. CWL input will be invalidated when you set up Pr04 (Setup of over-travel inhibit input) to 1.Default is "Invalid (1)". You can select the action when the CCWL input is validated with the setup of Pr66 (Sequence at over-travel inhibit). Default is "Emergency stop with dynamic brake".(Pr66=0) 	SI P.193																											
damping control switching input	26	VS-SEL	<ul style="list-style-type: none"> Function varies depending on the control mode. <table border="1" style="width: 100%; border-collapse: collapse;"> <tr> <td rowspan="6" style="text-align: center; vertical-align: middle;">Velocity/ Torque control</td> <td colspan="3"> <ul style="list-style-type: none"> Becomes to a speed-zero clamp input (ZEROSPD). </td> </tr> <tr> <td style="text-align: center;">Pr06</td> <td style="text-align: center;">Connection to COM–</td> <td style="text-align: center;">Content</td> </tr> <tr> <td style="text-align: center;">0</td> <td style="text-align: center;">–</td> <td>ZEROSPD input is invalid.</td> </tr> <tr> <td rowspan="2" style="text-align: center;">1</td> <td style="text-align: center;">open</td> <td>Speed command is 0</td> </tr> <tr> <td style="text-align: center;">close</td> <td>Normal action</td> </tr> <tr> <td rowspan="2" style="text-align: center;">2</td> <td style="text-align: center;">open</td> <td>Speed command is to CCW</td> </tr> <tr> <td style="text-align: center;">close</td> <td>Speed command is to CW.</td> </tr> <tr> <td colspan="3"> <ul style="list-style-type: none"> In case Pr06 is 2 at torque control, ZEROSPD is invalid. </td> </tr> <tr> <td rowspan="2" style="text-align: center; vertical-align: middle;">Position/ Full-closed control</td> <td colspan="3"> <ul style="list-style-type: none"> Becomes to an input of damping control switching (VS-SEL). While Pr24 (Damping filter switching selection) is 1, the 1st damping filter (Pr2B, Pr2C) will be validated when you open this input, and the 2nd damping filter (Pr2D, Pr2E) will be validated when you connect this input to COM–. </td> </tr> </table>	Velocity/ Torque control	<ul style="list-style-type: none"> Becomes to a speed-zero clamp input (ZEROSPD). 			Pr06	Connection to COM–	Content	0	–	ZEROSPD input is invalid.	1	open	Speed command is 0	close	Normal action	2	open	Speed command is to CCW	close	Speed command is to CW.	<ul style="list-style-type: none"> In case Pr06 is 2 at torque control, ZEROSPD is invalid. 			Position/ Full-closed control	<ul style="list-style-type: none"> Becomes to an input of damping control switching (VS-SEL). While Pr24 (Damping filter switching selection) is 1, the 1st damping filter (Pr2B, Pr2C) will be validated when you open this input, and the 2nd damping filter (Pr2D, Pr2E) will be validated when you connect this input to COM–. 			SI P.193
Velocity/ Torque control	<ul style="list-style-type: none"> Becomes to a speed-zero clamp input (ZEROSPD). 																														
	Pr06	Connection to COM–	Content																												
	0	–	ZEROSPD input is invalid.																												
	1	open	Speed command is 0																												
		close	Normal action																												
	2	open	Speed command is to CCW																												
close		Speed command is to CW.																													
<ul style="list-style-type: none"> In case Pr06 is 2 at torque control, ZEROSPD is invalid. 																															
Position/ Full-closed control	<ul style="list-style-type: none"> Becomes to an input of damping control switching (VS-SEL). While Pr24 (Damping filter switching selection) is 1, the 1st damping filter (Pr2B, Pr2C) will be validated when you open this input, and the 2nd damping filter (Pr2D, Pr2E) will be validated when you connect this input to COM–. 																														
	Gain switching input or Torque limit switching input	27	GAIN TL-SEL	<ul style="list-style-type: none"> Function varies depending on the setups of Pr30 (2nd gain setup) and Pr03 (Selection of torque limit). <table border="1" style="width: 100%; border-collapse: collapse;"> <tr> <td style="text-align: center;">Pr03</td> <td style="text-align: center;">Pr30</td> <td style="text-align: center;">Connection to COM–</td> <td style="text-align: center;">Content</td> </tr> <tr> <td rowspan="4" style="text-align: center;">0 – 2</td> <td rowspan="2" style="text-align: center;">0</td> <td style="text-align: center;">open</td> <td>Velocity loop : PI (Proportion/Integration) action</td> </tr> <tr> <td style="text-align: center;">close</td> <td>Velocity loop : P (Proportion) action</td> </tr> <tr> <td rowspan="3" style="text-align: center;">1</td> <td colspan="2" style="text-align: center;">when the setups of Pr31 and Pr36 are 2</td> </tr> <tr> <td style="text-align: center;">open</td> <td>1st gain selection (Pr10,11,12,13 and 14)</td> </tr> <tr> <td style="text-align: center;">close</td> <td>2nd gain selection (Pr18,19,1A,1B and 1C)</td> </tr> <tr> <td colspan="2" style="text-align: center;">when the setups of Pr31 and Pr36 are other than 2</td> <td style="text-align: center;">invalid</td> </tr> <tr> <td style="text-align: center;">3</td> <td style="text-align: center;">–</td> <td colspan="2"> <ul style="list-style-type: none"> Input of torque limit switching (TL-SEL) Pr5E (Setup of 1st torque limit) will be validated when you open this input, and Pr5F (Setup of 2nd torque limit) will be validated when you connect this input to COM–. </td> </tr> </table> <ul style="list-style-type: none"> For details of 2nd gain switching function, refer to P.243 "Gain Switching Function" of Adjustment. 	Pr03	Pr30	Connection to COM–	Content	0 – 2	0	open	Velocity loop : PI (Proportion/Integration) action	close	Velocity loop : P (Proportion) action	1	when the setups of Pr31 and Pr36 are 2		open	1st gain selection (Pr10,11,12,13 and 14)	close	2nd gain selection (Pr18,19,1A,1B and 1C)	when the setups of Pr31 and Pr36 are other than 2		invalid	3	–	<ul style="list-style-type: none"> Input of torque limit switching (TL-SEL) Pr5E (Setup of 1st torque limit) will be validated when you open this input, and Pr5F (Setup of 2nd torque limit) will be validated when you connect this input to COM–. 		SI P.193		
Pr03	Pr30	Connection to COM–	Content																												
0 – 2	0	open	Velocity loop : PI (Proportion/Integration) action																												
		close	Velocity loop : P (Proportion) action																												
	1	when the setups of Pr31 and Pr36 are 2																													
		open	1st gain selection (Pr10,11,12,13 and 14)																												
close		2nd gain selection (Pr18,19,1A,1B and 1C)																													
when the setups of Pr31 and Pr36 are other than 2		invalid																													
3	–	<ul style="list-style-type: none"> Input of torque limit switching (TL-SEL) Pr5E (Setup of 1st torque limit) will be validated when you open this input, and Pr5F (Setup of 2nd torque limit) will be validated when you connect this input to COM–. 																													

Wiring to the Connector, CN X5

of signal	Pin No.	Symbol	Function	I/F circuit																		
Electronic gear (division/multiplication) switching input	28	DIV	<ul style="list-style-type: none"> Function varies depending on the control mode. <table border="1"> <tr> <td>Position/ Full-closed control</td> <td> <ul style="list-style-type: none"> You can switch the numerator of electronic gear. By connecting to COM-, you can switch the numerator of electronic gear from Pr48 (1st numerator of electronic gear) to Pr49 (2nd numerator of electronic gear) For the selection of command division/multiplication, refer to the table of next page, "Numerator selection of command scaling" </td> </tr> <tr> <td>Velocity control</td> <td> <ul style="list-style-type: none"> Input of internal speed selection 3 (INTSPD3). You can make up to 8-speed setups combining INH/INTSPD1 and CL/INTSPD2 inputs. For details of setup, refer to the table of P.131, "Selection of Internal Speed". </td> </tr> <tr> <td>Torque control</td> <td> <ul style="list-style-type: none"> This input is invalid. </td> </tr> </table> <p><Caution> Do not enter the command pulse 10ms before/after switching.</p>	Position/ Full-closed control	<ul style="list-style-type: none"> You can switch the numerator of electronic gear. By connecting to COM-, you can switch the numerator of electronic gear from Pr48 (1st numerator of electronic gear) to Pr49 (2nd numerator of electronic gear) For the selection of command division/multiplication, refer to the table of next page, "Numerator selection of command scaling" 	Velocity control	<ul style="list-style-type: none"> Input of internal speed selection 3 (INTSPD3). You can make up to 8-speed setups combining INH/INTSPD1 and CL/INTSPD2 inputs. For details of setup, refer to the table of P.131, "Selection of Internal Speed". 	Torque control	<ul style="list-style-type: none"> This input is invalid. 	SI P.193												
Position/ Full-closed control	<ul style="list-style-type: none"> You can switch the numerator of electronic gear. By connecting to COM-, you can switch the numerator of electronic gear from Pr48 (1st numerator of electronic gear) to Pr49 (2nd numerator of electronic gear) For the selection of command division/multiplication, refer to the table of next page, "Numerator selection of command scaling" 																					
Velocity control	<ul style="list-style-type: none"> Input of internal speed selection 3 (INTSPD3). You can make up to 8-speed setups combining INH/INTSPD1 and CL/INTSPD2 inputs. For details of setup, refer to the table of P.131, "Selection of Internal Speed". 																					
Torque control	<ul style="list-style-type: none"> This input is invalid. 																					
Servo-ON input	29	SRV-ON	<ul style="list-style-type: none"> Turns to Servo-ON status by connecting this input to COM-. Turns to Servo-OFF status by opening connection to COM-, and current to the motor will be shut off. You can select the dynamic brake action and the deviation counter clearing action at Servo-OFF with Pr69 (Sequence at Servo-OFF). <p><Caution></p> <ol style="list-style-type: none"> Servo-ON input becomes valid approx. 2 sec after power-on. (see P.42, "Timing Chart" of Preparation.) Never run/stop the motor with Servo-ON/OFF. After shifting to Servo-ON, allow 100ms or longer pause before entering the pulse command. 	SI P.193																		
Deviation counter clear input	30	CL	<ul style="list-style-type: none"> Function varies depending on the control mode. <table border="1"> <tr> <td rowspan="4">Position/ Full-closed control</td> <td colspan="2"> <ul style="list-style-type: none"> Input (CL) which clears the positional deviation counter and full-closed deviation counter. You can clear the counter of positional deviation and full-closed deviation by connecting this to COM-. You can select the clearing mode with Pr4E (Counter clear input mode).. </td> </tr> <tr> <th>Pr4E</th> <th>Content</th> </tr> <tr> <td>0</td> <td>Clears the counter of positional deviation and full-closed deviation while CL is connected to COM-.</td> </tr> <tr> <td>1 [Default]</td> <td>Clears the counter of positional deviation and full-closed deviation only once by connecting CL to COM- from open status.</td> </tr> <tr> <td></td> <td>2</td> <td>CL is invalid</td> </tr> <tr> <td>Velocity control</td> <td colspan="2"> <ul style="list-style-type: none"> Input of selection 2 of internal command speed (INTSPD2) You can make up to 8-speed setups combining INH/INTSPD1 and CL/INTSPD3 inputs. For details of setup, refer to the table in P.131, "Selection of Internal Speed" of Velocity Control Mode. </td> </tr> <tr> <td>Torque control</td> <td colspan="2"> <ul style="list-style-type: none"> This input is invalid. </td> </tr> </table>	Position/ Full-closed control	<ul style="list-style-type: none"> Input (CL) which clears the positional deviation counter and full-closed deviation counter. You can clear the counter of positional deviation and full-closed deviation by connecting this to COM-. You can select the clearing mode with Pr4E (Counter clear input mode).. 		Pr4E	Content	0	Clears the counter of positional deviation and full-closed deviation while CL is connected to COM-.	1 [Default]	Clears the counter of positional deviation and full-closed deviation only once by connecting CL to COM- from open status.		2	CL is invalid	Velocity control	<ul style="list-style-type: none"> Input of selection 2 of internal command speed (INTSPD2) You can make up to 8-speed setups combining INH/INTSPD1 and CL/INTSPD3 inputs. For details of setup, refer to the table in P.131, "Selection of Internal Speed" of Velocity Control Mode. 		Torque control	<ul style="list-style-type: none"> This input is invalid. 		SI P.193
Position/ Full-closed control	<ul style="list-style-type: none"> Input (CL) which clears the positional deviation counter and full-closed deviation counter. You can clear the counter of positional deviation and full-closed deviation by connecting this to COM-. You can select the clearing mode with Pr4E (Counter clear input mode).. 																					
	Pr4E	Content																				
	0	Clears the counter of positional deviation and full-closed deviation while CL is connected to COM-.																				
	1 [Default]	Clears the counter of positional deviation and full-closed deviation only once by connecting CL to COM- from open status.																				
	2	CL is invalid																				
Velocity control	<ul style="list-style-type: none"> Input of selection 2 of internal command speed (INTSPD2) You can make up to 8-speed setups combining INH/INTSPD1 and CL/INTSPD3 inputs. For details of setup, refer to the table in P.131, "Selection of Internal Speed" of Velocity Control Mode. 																					
Torque control	<ul style="list-style-type: none"> This input is invalid. 																					
Alarm clear input	31	A-CLR	<ul style="list-style-type: none"> You can release the alarm status by connecting this to COM- for more than 120ms. The deviation counter will be cleared at alarm clear. There are some alarms which cannot be released with this input. For details, refer to P.252, "Protective Function" of When in Trouble. 	SI P.193																		

[Connection and Setup of Full-closed Control]

Title of signal	Pin No.	Symbol	Function	I/F circuit						
Control mode switching input	33	INH	<ul style="list-style-type: none"> Function varies depending on the control mode. 	<div style="border: 1px solid black; padding: 2px;">SI</div> P.193						
			Position/ Full closed control <ul style="list-style-type: none"> Inhibition input of command pulse input (INH) Ignores the position command pulse by opening the connection to COM- You can invalidate this input with Pr43 (Invalidation of command pulse inhibition input) <table border="1" style="width: 100%; border-collapse: collapse;"> <thead> <tr> <th style="width: 30%;">Pr43</th> <th>Content</th> </tr> </thead> <tbody> <tr> <td style="text-align: center;">0</td> <td>INH is valid.</td> </tr> <tr> <td style="text-align: center;">1(Default)</td> <td>INH is valid.</td> </tr> </tbody> </table>		Pr43	Content	0	INH is valid.	1(Default)	INH is valid.
			Pr43		Content					
			0		INH is valid.					
1(Default)	INH is valid.									
Velocity control <ul style="list-style-type: none"> Selection 1 input of internal command speed (INTSPD1) You can make up to 8-speed setups combining INH/INTSPD2 and CL/INTSPD3 inputs. For details of the setup, refer to the table of P.131, "Selection of Internal Speed" of Velocity Control Mode. 										
Torque control <ul style="list-style-type: none"> This input is invalid. 										

• Numerator selection of electronic gear

CN X5 Pin-28 DIV	Setup of electronic gear
Open	$\frac{\text{1st numerator of electronic gear (Pr48)} \times 2^{\text{Multiplier of command scaling (Pr4A)}}}{\text{Denominator of electronic gear (Pr4B)} \times \text{Encoder resolution}^*}$
	$\frac{\text{Command pulse counts per single turn (Pr4B)}}{\text{Encoder resolution}^*}$ <p style="text-align: right; font-size: small;">* Automatic setup by setting up Pr48 to 0</p>
Short	$\frac{\text{2nd numerator of electronic gear (Pr49)} \times 2^{\text{Multiplier of command scaling (Pr4A)}}}{\text{Denominator of electronic gear (Pr4B)} \times \text{Encoder resolution}^*}$
	$\frac{\text{Command pulse counts per single turn (Pr4B)}}{\text{Encoder resolution}^*}$ <p style="text-align: right; font-size: small;">* Automatic setup by setting up Pr49 to 0</p>

Wiring to the Connector, CN X5

Input Signals (Pulse Train) and Their Functions

You can select appropriate interface out of two kinds, depending on the command pulse specifications.

• Pulse train interface exclusive for line driver

Title of signal	Pin No.	Symbol	Function	I/F circuit
Command pulse input 1	44	PULSH1	<ul style="list-style-type: none"> Input terminal for position command pulse. You can select by setting up Pr40 (Selection of command pulse input) to 1. This input becomes invalid at such control mode as velocity control or torque control, where no position command is required. Permissible max. input frequency is 2Mpps. 	PI2 P.193
	45	PULSH2		
Command pulse sign input 1	46	SIGNH1	<ul style="list-style-type: none"> You can select up to 6 command pulse input formats with Pr41 (Setup of command pulse rotational direction) and Pr42 (Setup of command pulse input mode). 	
	47	SIGNH2		

• Pulse train interface

Title of signal	Pin No.	Symbol	Function	I/F circuit
Command pulse input 2	1	OPC1	<ul style="list-style-type: none"> Input terminal for the position command. You can select by setting up Pr40 (Selection of command pulse input) to 0. This input becomes invalid at such control mode as the velocity control or torque control, where no position command is required. Permissible max. input frequency is 500kpps at line driver input and 200kpps at open collector input. 	PI1 P.193
	3	PULS1		
	4	PULS2		
Command pulse sign input 2	2	OPC2	<ul style="list-style-type: none"> You can select up to 6 command pulse input formats with Pr41 (Setup of command pulse rotational direction) and Pr42 (Setup of command pulse input mode). 	
	5	SIGN1		
	6	SIGN2		

• Command pulse input format

Pr41 Setup value (Setup of command pulse rotational direction)	Pr42 Setup value (Setup of command pulse input mode)	Command pulse format	Signal title	CCW command	CW command
0	0 or 2	2-phase pulse with 90° difference (A+B-phase)	PULS SIGN	<p>B-phase advances to A by 90°.</p>	<p>B-phase delays from A by 90°.</p>
	1	CW pulse train + CCW pulse train	PULS SIGN		
	3	Pulse train + Sign	PULS SIGN	<p>"H"</p>	<p>"L"</p>
1	0 or 2	2-phase pulse with 90° difference (A+B-phase)	PULS SIGN	<p>B-phase delays from A by 90°.</p>	<p>B-phase advances to A by 90°.</p>
	1	CW pulse train + CCW pulse train	PULS SIGN		
	3	Pulse train + Sign	PULS SIGN	<p>"L"</p>	<p>"H"</p>

- PULS and SIGN represents the outputs of pulse train in put circuit. Refer to the fig. of P.193, "Input Circuit".
- In case of CW pulse train + CCW pulse train and pulse train + sign, pulse train will be captured at the rising edge.
- In case of 2-phase pulse, pulse train will be captured at each edge.

• Permissible max. input frequency of command pulse input signal and min. necessary time width

Input I/F of PULS/SIGN signal	Permissible max. input frequency	Minimum necessary time width					
		t1	t2	t3	t4	t5	t6
Pulse train interface exclusive for line driver	2Mpps	500ns	250ns	250ns	250ns	250ns	250ns
Pulse train interface	Line driver interface	2μs	1μs	1μs	1μs	1μs	1μs
	Open collector interface	200kpps	5μs	2.5μs	2.5μs	2.5μs	2.5μs

Set up the rising/falling time of command pulse input signal to 0.1μs or shorter.

Input Signals (Analog Command) and Their Functions

Title of signal	Pin No.	Symbol	Function	I/F circuit										
Speed command input or Torque command input, or Speed limit input	14	SPR	• Function varies depending on control mode.	<div style="border: 1px solid black; padding: 2px; display: inline-block;">AI</div> P.193										
		TRQR	<table border="1" style="width: 100%; border-collapse: collapse;"> <thead> <tr> <th>Pr02</th> <th>Control mode</th> <th>Function</th> </tr> </thead> <tbody> <tr> <td>1</td> <td><u>Velocity control</u></td> <td rowspan="3"> <ul style="list-style-type: none"> External velocity command input (SPR) when the velocity control is selected. Set up the gain, polarity, offset and filter of the speed command with; Pr50 (Speed command input gain) Pr51 (Speed command input reversal) Pr52 (Speed command offset) Pr57 (Speed command filter setup) </td> </tr> <tr> <td>3</td> <td><u>Position/Velocity</u></td> </tr> <tr> <td>5</td> <td><u>Velocity/Torque</u></td> </tr> </tbody> </table>		Pr02	Control mode	Function	1	<u>Velocity control</u>	<ul style="list-style-type: none"> External velocity command input (SPR) when the velocity control is selected. Set up the gain, polarity, offset and filter of the speed command with; Pr50 (Speed command input gain) Pr51 (Speed command input reversal) Pr52 (Speed command offset) Pr57 (Speed command filter setup) 	3	<u>Position/Velocity</u>	5	<u>Velocity/Torque</u>
		Pr02	Control mode		Function									
		1	<u>Velocity control</u>		<ul style="list-style-type: none"> External velocity command input (SPR) when the velocity control is selected. Set up the gain, polarity, offset and filter of the speed command with; Pr50 (Speed command input gain) Pr51 (Speed command input reversal) Pr52 (Speed command offset) Pr57 (Speed command filter setup) 									
		3	<u>Position/Velocity</u>											
		5	<u>Velocity/Torque</u>											
SPL	<table border="1" style="width: 100%; border-collapse: collapse;"> <thead> <tr> <th>Pr5B</th> <th>Content</th> </tr> </thead> <tbody> <tr> <td>0</td> <td> <ul style="list-style-type: none"> Torque command (TRQR) will be selected. Set up the torque (TRQR) gain, polarity, offset and filter with; Pr5C (Torque command input gain) Pr5D (Torque command input reversal) Pr52 (Speed command offset) Pr57 (Speed command filter setup) </td> </tr> <tr> <td>1</td> <td> <ul style="list-style-type: none"> Speed limit (SPL) will be selected. Set up the speed limit (SPL) gain, offset and filter with; Pr50 (Speed command input gain) Pr52 (Speed command offset) Pr57 (Speed command filter setup) </td> </tr> </tbody> </table>	Pr5B	Content	0	<ul style="list-style-type: none"> Torque command (TRQR) will be selected. Set up the torque (TRQR) gain, polarity, offset and filter with; Pr5C (Torque command input gain) Pr5D (Torque command input reversal) Pr52 (Speed command offset) Pr57 (Speed command filter setup) 	1	<ul style="list-style-type: none"> Speed limit (SPL) will be selected. Set up the speed limit (SPL) gain, offset and filter with; Pr50 (Speed command input gain) Pr52 (Speed command offset) Pr57 (Speed command filter setup) 							
Pr5B	Content													
0	<ul style="list-style-type: none"> Torque command (TRQR) will be selected. Set up the torque (TRQR) gain, polarity, offset and filter with; Pr5C (Torque command input gain) Pr5D (Torque command input reversal) Pr52 (Speed command offset) Pr57 (Speed command filter setup) 													
1	<ul style="list-style-type: none"> Speed limit (SPL) will be selected. Set up the speed limit (SPL) gain, offset and filter with; Pr50 (Speed command input gain) Pr52 (Speed command offset) Pr57 (Speed command filter setup) 													
	<table border="1" style="width: 100%; border-collapse: collapse;"> <thead> <tr> <th>Pr5B</th> <th>Content</th> </tr> </thead> <tbody> <tr> <td>0</td> <td>• This input becomes invalid.</td> </tr> <tr> <td>1</td> <td> <ul style="list-style-type: none"> Speed limit (SPL) will be selected. Set up velocity limit (SPL) gain, offset and filter with; Pr50 (Speed command input gain) Pr52 (Speed command offset) Pr57 (Speed command filter setup) </td> </tr> </tbody> </table>	Pr5B	Content	0	• This input becomes invalid.	1	<ul style="list-style-type: none"> Speed limit (SPL) will be selected. Set up velocity limit (SPL) gain, offset and filter with; Pr50 (Speed command input gain) Pr52 (Speed command offset) Pr57 (Speed command filter setup) 							
Pr5B	Content													
0	• This input becomes invalid.													
1	<ul style="list-style-type: none"> Speed limit (SPL) will be selected. Set up velocity limit (SPL) gain, offset and filter with; Pr50 (Speed command input gain) Pr52 (Speed command offset) Pr57 (Speed command filter setup) 													
Others	<table border="1" style="width: 100%; border-collapse: collapse;"> <thead> <tr> <th>Other control mode</th> <th>Function</th> </tr> </thead> <tbody> <tr> <td></td> <td>• This input is invalid.</td> </tr> </tbody> </table>	Other control mode	Function		• This input is invalid.									
Other control mode	Function													
	• This input is invalid.													
•The resolution of the A/D converter used in this input is 16 bit (including 1 bit for sign). ± 32767 (LSB) = ± 10 [V], 1[LSB] = 0.3[mV]														

*Function becomes valid when the control mode with underline (/)

<Remark>

Do not apply voltage exceeding ±10V to analog command inputs of SPR/TRQR/SPL.

Wiring to the Connector, CN X5

Title of signal	Pin No.	Symbol	Function	I/F circuit																		
CCW-Torque limit input	16	CCWTL	<ul style="list-style-type: none"> Function varies depending on Pr02 (Control mode setup). <table border="1"> <thead> <tr> <th>Pr02</th> <th>Control mode</th> <th>Function</th> </tr> </thead> <tbody> <tr> <td rowspan="2">2 4</td> <td rowspan="2"><u>Torque Control</u> <u>Position/Torque</u></td> <td> <ul style="list-style-type: none"> Function varies depending on Pr5B (Selection of torque command) <table border="1"> <thead> <tr> <th>Pr5B</th> <th>Content</th> </tr> </thead> <tbody> <tr> <td>0</td> <td>This input becomes invalid.</td> </tr> <tr> <td>1</td> <td> <ul style="list-style-type: none"> Torque command input (TRQR) will be selected. Set up the gain and polarity of the command with; <ul style="list-style-type: none"> Pr5C (Torque command input gain) Pr5D (Torque command input reversal) Offset and filter cannot be set up. </td> </tr> </tbody> </table> </td> </tr> <tr> <td>5</td> <td><u>Velocity/Torque</u></td> <td> <ul style="list-style-type: none"> Becomes to the torque command input (TRQR). Set up the gain and polarity of the command with; <ul style="list-style-type: none"> Pr5C (Torque command input gain) Pr5D (Torque command input reversal) Offset and filter cannot be set up. </td> </tr> <tr> <td>4 5 Other</td> <td><u>Position/Torque</u> <u>Velocity/Torque</u> Other control mode</td> <td> <ul style="list-style-type: none"> Becomes to the analog torque limit input to CCW (CCWTL). Limit the CCW-torque by applying positive voltage (0 to +10V) (Approx.+3V/rated torque) Invalidate this input by setting up Pr03 (Torque limit selection) to other than 0. </td> </tr> </tbody> </table> <ul style="list-style-type: none"> Resolution of A/D converter used in this input is 16 bit (including 1 bit for sign). ± 511 [LSB] = ± 11.9[V], 1 [LSB] \cong 23[mV] 	Pr02	Control mode	Function	2 4	<u>Torque Control</u> <u>Position/Torque</u>	<ul style="list-style-type: none"> Function varies depending on Pr5B (Selection of torque command) <table border="1"> <thead> <tr> <th>Pr5B</th> <th>Content</th> </tr> </thead> <tbody> <tr> <td>0</td> <td>This input becomes invalid.</td> </tr> <tr> <td>1</td> <td> <ul style="list-style-type: none"> Torque command input (TRQR) will be selected. Set up the gain and polarity of the command with; <ul style="list-style-type: none"> Pr5C (Torque command input gain) Pr5D (Torque command input reversal) Offset and filter cannot be set up. </td> </tr> </tbody> </table>	Pr5B	Content	0	This input becomes invalid.	1	<ul style="list-style-type: none"> Torque command input (TRQR) will be selected. Set up the gain and polarity of the command with; <ul style="list-style-type: none"> Pr5C (Torque command input gain) Pr5D (Torque command input reversal) Offset and filter cannot be set up. 	5	<u>Velocity/Torque</u>	<ul style="list-style-type: none"> Becomes to the torque command input (TRQR). Set up the gain and polarity of the command with; <ul style="list-style-type: none"> Pr5C (Torque command input gain) Pr5D (Torque command input reversal) Offset and filter cannot be set up. 	4 5 Other	<u>Position/Torque</u> <u>Velocity/Torque</u> Other control mode	<ul style="list-style-type: none"> Becomes to the analog torque limit input to CCW (CCWTL). Limit the CCW-torque by applying positive voltage (0 to +10V) (Approx.+3V/rated torque) Invalidate this input by setting up Pr03 (Torque limit selection) to other than 0. 	<div style="border: 1px solid black; padding: 2px; display: inline-block;">AI</div> P.193
			Pr02	Control mode	Function																	
2 4	<u>Torque Control</u> <u>Position/Torque</u>	<ul style="list-style-type: none"> Function varies depending on Pr5B (Selection of torque command) <table border="1"> <thead> <tr> <th>Pr5B</th> <th>Content</th> </tr> </thead> <tbody> <tr> <td>0</td> <td>This input becomes invalid.</td> </tr> <tr> <td>1</td> <td> <ul style="list-style-type: none"> Torque command input (TRQR) will be selected. Set up the gain and polarity of the command with; <ul style="list-style-type: none"> Pr5C (Torque command input gain) Pr5D (Torque command input reversal) Offset and filter cannot be set up. </td> </tr> </tbody> </table>	Pr5B	Content	0	This input becomes invalid.	1	<ul style="list-style-type: none"> Torque command input (TRQR) will be selected. Set up the gain and polarity of the command with; <ul style="list-style-type: none"> Pr5C (Torque command input gain) Pr5D (Torque command input reversal) Offset and filter cannot be set up. 														
		Pr5B	Content																			
0	This input becomes invalid.																					
1	<ul style="list-style-type: none"> Torque command input (TRQR) will be selected. Set up the gain and polarity of the command with; <ul style="list-style-type: none"> Pr5C (Torque command input gain) Pr5D (Torque command input reversal) Offset and filter cannot be set up. 																					
5	<u>Velocity/Torque</u>	<ul style="list-style-type: none"> Becomes to the torque command input (TRQR). Set up the gain and polarity of the command with; <ul style="list-style-type: none"> Pr5C (Torque command input gain) Pr5D (Torque command input reversal) Offset and filter cannot be set up. 																				
4 5 Other	<u>Position/Torque</u> <u>Velocity/Torque</u> Other control mode	<ul style="list-style-type: none"> Becomes to the analog torque limit input to CCW (CCWTL). Limit the CCW-torque by applying positive voltage (0 to +10V) (Approx.+3V/rated torque) Invalidate this input by setting up Pr03 (Torque limit selection) to other than 0. 																				
<ul style="list-style-type: none"> Resolution of A/D converter used in this input is 16 bit (including 1 bit for sign). ± 511 [LSB] = ± 11.9[V], 1 [LSB] \cong 23[mV] 																						
CW-Torque limit input	18	CWTL	<ul style="list-style-type: none"> Function varies depending on Pr02 (Control mode setup). <table border="1"> <thead> <tr> <th>Pr02</th> <th>Control mode</th> <th>Function</th> </tr> </thead> <tbody> <tr> <td>2 4 5</td> <td><u>Torque control</u> <u>Position/Torque</u> <u>Velocity/Torque</u></td> <td> <ul style="list-style-type: none"> This input becomes invalid when the torque control is selected. </td> </tr> <tr> <td>4 5 Other</td> <td><u>Position/Torque</u> <u>Velocity/Torque</u> Other control mode</td> <td> <ul style="list-style-type: none"> Becomes to the analog torque limit input to CW (CWTL). Limit the CW-torque by applying negative voltage (0 – -10V) (Approx.+3V/rated torque). Invalidate this input by setting up Pr03 (Torque limit selection) to other than 0. </td> </tr> </tbody> </table> <ul style="list-style-type: none"> Resolution of A/D converter used in this input is 16 bit (including 1 bit for sign). ± 511 [LSB] = ± 11.9[V], 1 [LSB] \cong 23[mV] 	Pr02	Control mode	Function	2 4 5	<u>Torque control</u> <u>Position/Torque</u> <u>Velocity/Torque</u>	<ul style="list-style-type: none"> This input becomes invalid when the torque control is selected. 	4 5 Other	<u>Position/Torque</u> <u>Velocity/Torque</u> Other control mode	<ul style="list-style-type: none"> Becomes to the analog torque limit input to CW (CWTL). Limit the CW-torque by applying negative voltage (0 – -10V) (Approx.+3V/rated torque). Invalidate this input by setting up Pr03 (Torque limit selection) to other than 0. 	<div style="border: 1px solid black; padding: 2px; display: inline-block;">AI</div> P.193									
			Pr02	Control mode	Function																	
2 4 5	<u>Torque control</u> <u>Position/Torque</u> <u>Velocity/Torque</u>	<ul style="list-style-type: none"> This input becomes invalid when the torque control is selected. 																				
4 5 Other	<u>Position/Torque</u> <u>Velocity/Torque</u> Other control mode	<ul style="list-style-type: none"> Becomes to the analog torque limit input to CW (CWTL). Limit the CW-torque by applying negative voltage (0 – -10V) (Approx.+3V/rated torque). Invalidate this input by setting up Pr03 (Torque limit selection) to other than 0. 																				
<ul style="list-style-type: none"> Resolution of A/D converter used in this input is 16 bit (including 1 bit for sign). ± 511 [LSB] = ± 11.9[V], 1 [LSB] \cong 23[mV] 																						

*Function becomes valid when the control mode with underline (/)

<Remark>

Do not apply voltage exceeding ± 10 V to analog command input of CWTL and CCWTL

Output signal and Pin No. of the Connector, CN X5

Output Signals (Common) and Their Functions

Title of signal	Pin No	Symbol	Function	I/F circuit						
External brake release signal	11	BRKOFF+	<ul style="list-style-type: none"> Feeds out the timing signal which activates the electromagnetic brake of the motor. Turns the output transistor ON at the release timing of the electromagnetic brake. You can set up the output timing of this signal with Pr6A (Setup of mechanical brake action at stall) and Pr6B (Setup of mechanical brake action at motion). For details, refer to P42, "Timing Chart" of Preparation.) 	SO1 P.194						
	10	BRKOFF-								
Servo-Ready output	35	S-RDY+	<ul style="list-style-type: none"> This signal shows that the driver is ready to be activated. Output transistor turns ON when both control and main power are ON but not at alarm status. 	SO1 P.194						
	34	S-RDY-								
Servo-Alarm output	37	ALM+	<ul style="list-style-type: none"> This signal shows that the driver is in alarm status.. Output transistor turns ON when the driver is at normal status, and turns OFF at alarm status. 	SO1 P.194						
	36	ALM-								
Positioning complete (In-position)	39 38	AT-SPEED+	<ul style="list-style-type: none"> Function varies depending on the control mode. <table border="1" style="width: 100%; border-collapse: collapse;"> <tr> <td style="width: 20%; text-align: center;">Position control</td> <td> <ul style="list-style-type: none"> Output of positioning complete (COIN) The output transistor will turn ON when the absolute value of the position deviation pulse becomes smaller than the setup value of Pr60 (Positioning complete range). You can select the feeding out method with Pr63 (Setup of positioning complete output). </td> </tr> <tr> <td style="text-align: center;">Full-closed control</td> <td> <ul style="list-style-type: none"> Output of full-closed positioning complete (EX-COIN) The output transistor will turn ON when the absolute value of full-closed-position deviation pulse becomes smaller than the setup value of Pr60 (Positioning complete range). You can select the feeding out method with Pr63 (Setup of positioning complete output). </td> </tr> <tr> <td style="text-align: center;">Velocity/Torque control</td> <td> <ul style="list-style-type: none"> Output at-speed (speed arrival) (AT-SPEED) The output transistor will turn ON when the actual motor speed exceeds the setup value of Pr62 (In-speed). </td> </tr> </table>	Position control	<ul style="list-style-type: none"> Output of positioning complete (COIN) The output transistor will turn ON when the absolute value of the position deviation pulse becomes smaller than the setup value of Pr60 (Positioning complete range). You can select the feeding out method with Pr63 (Setup of positioning complete output). 	Full-closed control	<ul style="list-style-type: none"> Output of full-closed positioning complete (EX-COIN) The output transistor will turn ON when the absolute value of full-closed-position deviation pulse becomes smaller than the setup value of Pr60 (Positioning complete range). You can select the feeding out method with Pr63 (Setup of positioning complete output). 	Velocity/Torque control	<ul style="list-style-type: none"> Output at-speed (speed arrival) (AT-SPEED) The output transistor will turn ON when the actual motor speed exceeds the setup value of Pr62 (In-speed). 	SO1 P.194
		Position control		<ul style="list-style-type: none"> Output of positioning complete (COIN) The output transistor will turn ON when the absolute value of the position deviation pulse becomes smaller than the setup value of Pr60 (Positioning complete range). You can select the feeding out method with Pr63 (Setup of positioning complete output). 						
		Full-closed control		<ul style="list-style-type: none"> Output of full-closed positioning complete (EX-COIN) The output transistor will turn ON when the absolute value of full-closed-position deviation pulse becomes smaller than the setup value of Pr60 (Positioning complete range). You can select the feeding out method with Pr63 (Setup of positioning complete output). 						
Velocity/Torque control	<ul style="list-style-type: none"> Output at-speed (speed arrival) (AT-SPEED) The output transistor will turn ON when the actual motor speed exceeds the setup value of Pr62 (In-speed). 									
AT-SPEED-										
Zero-speed detection output signal	12 (41)	ZSP (COM-)	<ul style="list-style-type: none"> Content of the output signal varies depending on Pr0A (Selection of ZSP output). Default is 1, and feeds out the zero speed detection signal. For details, see the table below, "Selection of TLC,ZSP output". 	SO2 P.194						
Torque in-limit signal output	40 (41)	TLC (COM-)	<ul style="list-style-type: none"> Content of the output signal varies depending on Pr09 (Selection of TLC output). Default is 1, and feeds out the torque in-limit signal. For details, see the table below, "Selection of TLC,ZSP output". 	SO2 P.194						

• Selection of TCL and ZSP outputs

	X5 TLC : Output of Pin-40	X5 ZSP : Output of Pin-12
0	<ul style="list-style-type: none"> Torque in-limit output (Default of X5 TLC Pr09) The output transistor turns ON when the torque command is limited by the torque limit during Servo-ON. 	
1	<ul style="list-style-type: none"> Zero-speed detection output (Default of X5 ZSP Pr0A) The output transistor turns ON when the motor speed falls under the preset value with Pr61. 	
2	<ul style="list-style-type: none"> Alarm signal output The output transistor turns ON when either one of the alarms is triggered, over-regeneration alarm, overload alarm, battery alarm, fan-lock alarm or external scale alarm. 	
3	<ul style="list-style-type: none"> Over-regeneration alarm The output transistor turns ON when the regeneration exceeds 85% of the alarm trigger level of the regenerative load protection. 	
4	<ul style="list-style-type: none"> Over-load alarm The output transistor turns ON when the load exceeds 85% of the alarm trigger level of the overload alarm. 	
5	<ul style="list-style-type: none"> Battery alarm The output transistor turns ON when the battery voltage for absolute encoder falls lower than approx. 3.2V. 	
6	<ul style="list-style-type: none"> Fan-lock alarm The output transistor turns ON when the fan stalls for longer than 1s. 	
7	<ul style="list-style-type: none"> External scale alarm The output transistor turns ON when the external scale temperature exceeds 65°, or signal intensity is not enough (adjustment on mounting is required). Valid only at the full-closed control. 	
8	<ul style="list-style-type: none"> In-speed (Speed coincidence) output The output transistor turns ON when the difference between the actual motor speed and the speed command before acceleration/deceleration reaches within the preset range with Pr61. Valid only at the velocity and torque control. 	

Wiring to the Connector, CN X5

Output Signals (Pulse Train) and Their Functions

itle of signal	Pin No	Symbol	Function	I/F circuit
A-phase output	21	OA +	<ul style="list-style-type: none"> • Feeds out the divided encoder signal or external scale signal (A, B, Z-phase) in differential. (equivalent to RS422) • You can set up the division ratio with Pr44 (Numerator of pulse output division) and Pr45 (Denominator of pulse output division) • You can select the logic relation between A-phase and B-phase, and the output source with Pr46 (Reversal of pulse output logic). • When the external scale is made as an output source, you can set up the interval of Z-phase pulse output with Pr47 (Setup of external scale Z-phase). • Ground for line driver of output circuit is connected to signal ground (GND) and is not insulated. • Max. output frequency is 4Mpps (after quadrupled) 	<div style="border: 1px solid black; padding: 2px;">PO1</div> P.194
	22	OA -		
B-phase output	48	OB +		
	49	OB -		
Z-phase output	23	OZ +		
	24	OZ -		
Z-phase output	19	CZ	<ul style="list-style-type: none"> • Open collector output of Z-phase signal • The emitter side of the transistor of the output circuit is connected to the signal ground (GND) and is not insulated. 	<div style="border: 1px solid black; padding: 2px;">PO2</div> P.194

<Note>

• When the output source is the encoder

- If the encoder resolution $\times \frac{\text{Pr44}}{\text{Pr45}}$ is multiple of 4, Z-phase will be fed out synchronizing with A-phase.

In other case, the Z-phase width will be equal to the encoder resolution, and will not synchronize with A-phase because of narrower width than that of A-phase.

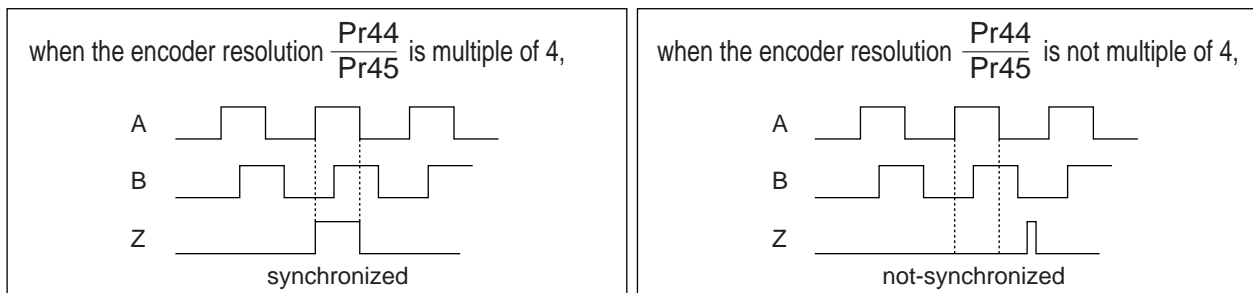

- In case of the 5-wire, 2500P/r incremental encoder, the signal sequence might not follow the above fig. until the first Z-phase is fed out. When you use the pulse output as the control signal, rotate the motor one revolution or more to make sure that the Z-phase is fed out at least once before using.

• When output source is the external scale,

- When the external scale is the output source, Z-phase pulse will not be fed out until the absolute position crosses 0 (000000000000h).
- Z-phase pulse after its crossing of the absolute position 0, will be fed out synchronizing with A-phase in every A-phase pulses which are set with Pr47 (External scale Z-phase setup)

Output Signals (Analog) and Their Functions

Title of signal	Pin No	Symbol	Function	I/F circuit		
Torque monitor signal output	42	IM	<ul style="list-style-type: none"> The content of output signal varies depending on Pr08 (Torque monitor (IM) selection). You can set up the scaling with Pr08 value. 	<div style="border: 1px solid black; padding: 2px; display: inline-block;">AO</div> P.194		
			Pr08		Content of signal	Function
			0, 11, 12		Torque command	<ul style="list-style-type: none"> Feeds out the voltage in proportion to the motor torque command with polarity. + : generates CCW torque - : generates CW torque
			1 – 5		Positional deviation	<ul style="list-style-type: none"> Feeds out the voltage in proportion to the positional deviation pulse counts with polarity. + : positional command to CCW of motor position - : positional command to CW of motor position
6 – 10	Full-closed deviation	<ul style="list-style-type: none"> Feeds out the voltage in proportion to the full-closed deviation pulse counts with polarity. + : positional command to CCW of external scale position - : positional command to CW of external scale position 				
Speed monitor signal output	43	SP	<ul style="list-style-type: none"> The content of the output signal varies depending on Pr07 (Speed monitor (IM) selection). You can set up the scaling with Pr07 value. 	<div style="border: 1px solid black; padding: 2px; display: inline-block;">AO</div> P.194		
			Pr07		Control mode	Function
			0 – 4		Motor speed	<ul style="list-style-type: none"> Feeds out the voltage in proportion to the motor speed with polarity. + : rotates to CCW - : rotates to CW
			5 – 9		Command speed	<ul style="list-style-type: none"> Feeds out the voltage in proportion to the command speed with polarity. + : rotates to CCW - : rotates to CW

Output Signals (Others) and Their Functions

Title of signal	Pin No	Symbol	Function	I/F circuit
Signal ground	13,15, 17,25	GND	<ul style="list-style-type: none"> Signal ground This output is insulated from the control signal power (COM-) inside of the driver. 	-
Frame ground	50	FG	<ul style="list-style-type: none"> This output is connected to the earth terminal inside of the driver. 	-

Wiring to the Connector, CN X7

Connector, CN X7

Power supply for the external scale shall be prepared by customer, or use the following power supply output for the external scale (250mA or less).

Application	Connector PinNo.	Content
Power supply output for external scale	1	EX5V
	2	EX0V
I/F of external scale signals (serial signal)	5	EXPS
	6	EXPS
Frame ground	Case	FG

<Note>

EX0V of the external scale power supply output is connected to the control circuit ground which is connected to the Connector, CN X5.

<Remark>

Do not connect anything to other Pin numbers described in the above table (Pin-3 and 4).

Cautions

(1) Following external scale can be used for full-closed control.

- AT500 series by Mitsutoyo
- ST771 by Mitsutoyo

(2) **Recommended external scale ratio is $1/20 < \text{External scale ratio} < 20$**

If you set up the external scale ratio to smaller value than $50 / \text{position loop gain (Pr10 and 18)}$, you may not be able to control per 1 pulse unit. Setup of larger scale ratio may result in larger noise.

Wiring to the External Scale, Connector, CN X7

Wire the signals from the external scale to the external scale connector, CN X7.

- 1) Cable for the external scale to be the twisted pair with bundle shielding and to having the twisted core wire with diameter of 0.18mm².
- 2) Cable length to be max. 20m. Double wiring for 5V power supply is recommended when the wiring length is long to reduce the voltage drop effect.
- 3) Connect the outer film of the shield wire of the external scale to the shield of the junction cable. Also connect the outer film of the shield wire to the shell (FG) of CN X7 of the driver without fail.
- 4) Separate the wiring to CN X7 from the power line (L1, L2, L3, L1C -, L2C (t), U, V, W, ⊕) as much as possible (30cm or more). Do not pass these wires in the same duct, nor bundle together.
- 5) Do not connect anything to the vacant pins of CN X7.

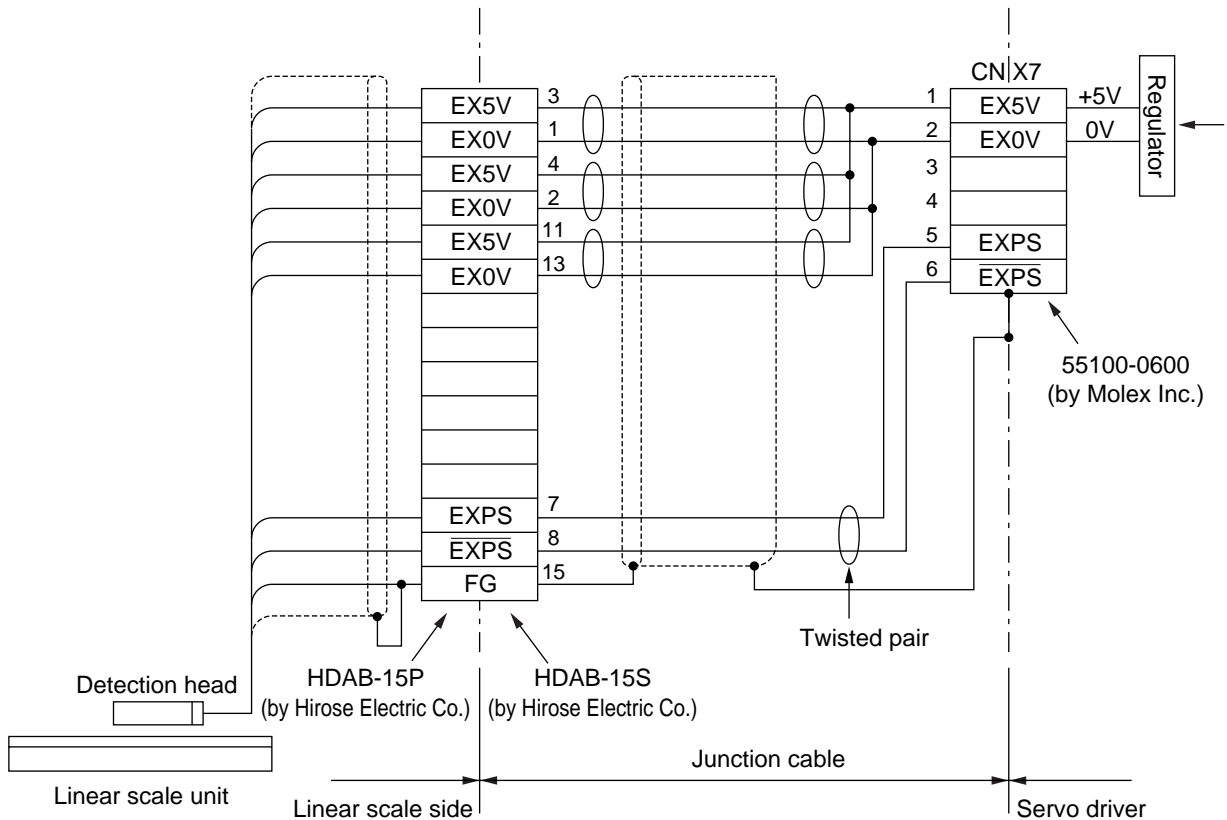

Real-Time Auto-Gain Tuning

Outline

The driver estimates the load inertia of the machine in real time, and automatically sets up the optimum gain responding to the result. Also the driver automatically suppress the vibration caused by the resonance with an adaptive filter.

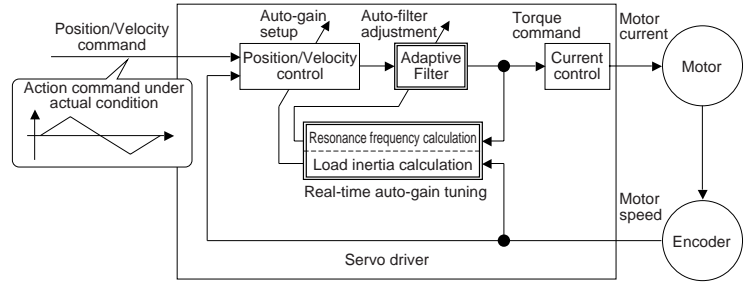

Applicable Range

- Real-time auto-gain tuning is applicable to all control modes.

Caution

Real-time auto-gain tuning may not be executed properly under the conditions described in the right table. In these cases, use the normal mode auto-gain tuning (refer to P.236 of Adjustment), or execute a manual gain tuning. (refer to P.240, of Adjustment)

Conditions which obstruct real-time auto-gain tuning	
Load inertia	<ul style="list-style-type: none"> • Load is too small or large compared to rotor inertia. (less than 3 times or more than 20 times) • Load inertia change too quickly. (10 [s] or less)
Load	<ul style="list-style-type: none"> • Machine stiffness is extremely low. • Chattering such as backlash exists.
Action pattern	<ul style="list-style-type: none"> • Motor is running continuously at low speed of 100 [r/min] or lower. • Acceleration/deceleration is slow (2000[r/min] per 1[s] or low). • Acceleration/deceleration torque is smaller than unbalanced weighted/viscous friction torque. • When speed condition of 100[r/min] or more and acceleration/deceleration condition of 2000[r/min] per 1[s] are not maintained for 50[ms].

How to Operate

- (1) Bring the motor to stall (Servo-OFF).
- (2) Set up Pr21 (Real-time auto-gain tuning mode setup) to 1-7. Default is 1.

Setup value	Real-time auto-gain tuning	Varying degree of load inertia in motion
0	(not in use)	—
<1>	normal mode	no change
2		slow change
3		rapid change
4	vertical axis mode	no change
5		slow change
6		rapid change
7	no-gain switching mode	no change

- When the varying degree of load inertia is large, set up 3 or 6.
- When the motor is used for vertical axis, set up 4-6.
- When vibration occurs during gain switching, set up 7.
- When resonance might give some effect, validate the setup of Pr23 (Setup of adaptive filter mode).

- (3) Set up Pr22 (Machine stiffness at real-time auto-gain tuning) to 0 or smaller value.
- (4) Turn to Servo-ON to run the machine normally.
- (5) Gradually increase Pr22 (Machine stiffness at real-time auto-gain tuning) when you want to obtain better response. Lower the value (0 to 3) when you experience abnormal noise or oscillation.
- (6) Write to EEPROM when you want to save the result.

Insert the console connector to CN X5 of the driver, then turn on the driver power. r 0

Setup of parameter, Pr21

Press **(S_{SET})**. dP_5Pd

Press **(M_{MODE})**. PR_00

Match to the parameter No. to be set up with **(▲▼)**. (Here match to Pr21.) PR_21

Press **(S_{SET})**. 1

Change the setup with **(▲▼)**.

Press **(S_{SET})**. PR_21

Setup of parameter, Pr22

Match to Pr22 with **(▲)**. PR_22

Press **(S_{SET})**. 4

Numerals increase with **(▲)**, and decrease with **(▼)**. (default values)

Press **(S_{SET})**.

Writing to EEPROM

Press **(M_{MODE})**. EE_SEt

Press **(S_{SET})**. EEP -

Bars increase as the right fig. shows by keep pressing **(▲)** (approx. 5sec). EEP --

Writing starts (temporary display). StArT

Finish FinIsh rESEt Error

Writing completes Writing error occurs

Return to SELECTION display after writing finishes, referring to "Structure of each mode"(P.60 and 61 of Preparation).

Adaptive Filters

The adaptive filter is validated by setting up Pr23 (Setup of adaptive filter mode) to other than 0.

The adaptive filter automatically estimates a resonance frequency out of vibration component presented in the motor speed in motion, then removes the resonance components from the torque command by setting up the notch filter coefficient automatically, hence reduces the resonance vibration.

The adaptive filter may not operate properly under the following conditions. In these cases, use 1st notch filter (Pr1D and 1E) and 2nd notch filter (Pr28-2A) to make measures against resonance according to the manual adjusting procedures.

For details of notch filters, refer to P.246, "Suppression of Machine Resonance" of Adjustment.

	Conditions which obstruct adaptive filter action
Resonance point	<ul style="list-style-type: none"> • When resonance frequency is lower than 300[Hz]. • While resonance peak is low or control gain is small and when no affect from these condition is given to the motor speed. • When multiple resonance points exist.
Load	<ul style="list-style-type: none"> • When the motor speed variation with high frequency factor is generated due to non-linear factor such as backlash.
Command pattern	<ul style="list-style-type: none"> • When acceleration/deceleration is very extreme such as more than 30000 [r/min] per 1 [s].

<Note>

Even though Pr23 is set up to other than 0, there are other cases when adaptive filter is automatically invalidated. Refer to P.235, "Invalidation of adaptive filter" of Adjustment.

Parameters Which Are Automatically Set Up.

Following parameters are automatically adjusted.

Also following parameters are automatically set up.

PrNo.	Title
10	1st gain of position loop
11	1st gain of velocity loop
12	1st time constant of velocity loop integration
13	1st filter of velocity detection
14	1st time constant of torque filter
18	2nd gain of position loop
19	2nd gain of velocity loop
1A	2nd time constant of velocity loop integration
1B	2nd filter of speed detection
1C	2nd time constant of torque filter
20	Inertia ratio
2F	Adaptive filter frequency

PrNo.	Title	Setup value
15	Velocity feed forward	300
16	Time constant of feed forward filter	50
27	Setup of instantaneous speed observer	0
30	2nd gain setup	1
31	1st mode of control switching	10
32	1st delay time of control switching	30
33	1st level of control switching	50
34	1st hysteresis of control switching	33
35	Position gain switching time	20
36	2nd mode of control switching	0

<Notes>

- When the real-time auto-gain tuning is valid, you cannot change parameters which are automatically adjusted.
- Pr31 becomes 10 at position or full closed control and when Pr21 (Setup of Real-Time Auto-Gain Tuning Mode) is 1-6, and becomes 0 in other cases.

Cautions

- (1) After the start-up, you may experience abnormal noise and oscillation right after the first Servo-ON, or when you increase the setup of Pr22 (Selection of machine stiffness at real-time auto-gain tuning), until load inertia is identified (estimated) or adaptive filter is stabilized, however, these are not failures as long as they disappear immediately. If they persist over 3 reciprocating operations, take the following measures in possible order.
 - 1) Write the parameters which have given the normal operation into EEPROM.
 - 2) Lower the setup of Pr22 (Selection of machine stiffness at real-time auto-gain tuning).
 - 3) Set up both Pr21 (Setup of real-time auto-gain tuning) and Pr23 (Setup of adaptive filter mode) to 0, then set up other value than 0. (Reset of inertia estimation and adaptive action)
 - 4) Invalidate the adaptive filter by setting up Pr23 (Setup of adaptive filter mode setup) to 0, and set up notch filter manually.
- (2) When abnormal noise and oscillation occur, Pr20 (Inertia ratio) or Pr2F (Adaptive filter frequency) might have changed to extreme values. Take the same measures as the above in these cases.
- (3) Among the results of real-time auto-gain tuning, Pr20 (Inertia ratio) and Pr2F (Adaptive filter frequency) will be written to EEPROM every 30 minutes. When you turn on the power again, auto-gain tuning will be executed using the latest data as initial values.
- (4) When you validate the real-time auto-gain tuning, Pr27 (Setup of instantaneous speed observer) will be invalidated automatically.
- (5) The adaptive filter is normally invalidated at torque control, however, when you select torque control while you set up Pr02 (Control mode setup) to 4 and 5, the adaptive filter frequency before mode switching will be held.
- (6) During the trial run and frequency characteristics measurement of "PANATERM[®]", the load inertia estimation will be invalidated.

Parameter Setup

Parameters for Functional Selection

Standard default : < >

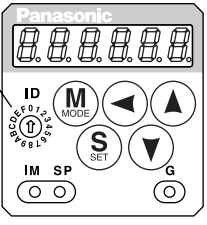
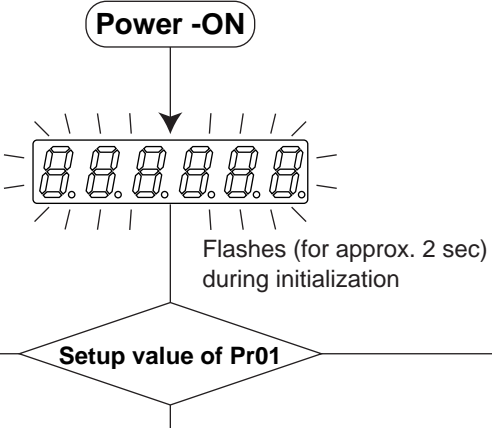
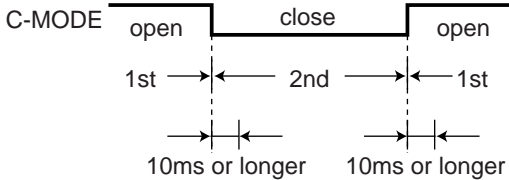
PrNo.	Title	Setup range	Function/Content																																						
00 *	Address	0 – 15 <1>	<p>In the communication with the host via RS232/485 for multi-axes application, it is necessary to identify which axis the host is communicating. Use this parameter to confirm the address of the axis in numbers.</p> <ul style="list-style-type: none"> The address is determined by the setup value of rotary switch (0-F) of the front panel at power-on. This value becomes the axis number at serial communication. The setup value of this parameter has no effect to the servo action. You cannot change the setup of Pr00 with other means than rotary switch. 																																						
01 *	LED initial status	0 – 17 <1>	<p>You can select the type of data to be displayed on the front panel LED (7 segment) at the initial status after power-on.</p> <div style="display: flex; align-items: flex-start;"> <div style="flex: 1;">  <p>Flashes (for approx. 2 sec) during initialization</p> <p>Setup value of Pr01</p> <p>For details of display, refer to P.51 "Setup of Parameter and Mode" of Preparation.</p> </div> <div style="flex: 1;"> <table border="1"> <thead> <tr> <th>Setup value</th> <th>Content</th> </tr> </thead> <tbody> <tr><td>0</td><td>Positional deviation</td></tr> <tr><td><1></td><td>Motor rotational speed</td></tr> <tr><td>2</td><td>Torque output</td></tr> <tr><td>3</td><td>Control mode</td></tr> <tr><td>4</td><td>I/O signal status</td></tr> <tr><td>5</td><td>Error factor/history</td></tr> <tr><td>6</td><td>Software version</td></tr> <tr><td>7</td><td>Alarm</td></tr> <tr><td>8</td><td>Regenerative load factor</td></tr> <tr><td>9</td><td>Over-load factor</td></tr> <tr><td>10</td><td>Inertia ratio</td></tr> <tr><td>11</td><td>Sum of feedback pulses</td></tr> <tr><td>12</td><td>Sum of command pulses</td></tr> <tr><td>13</td><td>External scale deviation</td></tr> <tr><td>14</td><td>Sum of external scale feedback pulses</td></tr> <tr><td>15</td><td>Motor automatic recognizing function</td></tr> <tr><td>16</td><td>Analog input value</td></tr> <tr><td>17</td><td>Factor of "No-Motor Running"</td></tr> </tbody> </table> </div> </div>	Setup value	Content	0	Positional deviation	<1>	Motor rotational speed	2	Torque output	3	Control mode	4	I/O signal status	5	Error factor/history	6	Software version	7	Alarm	8	Regenerative load factor	9	Over-load factor	10	Inertia ratio	11	Sum of feedback pulses	12	Sum of command pulses	13	External scale deviation	14	Sum of external scale feedback pulses	15	Motor automatic recognizing function	16	Analog input value	17	Factor of "No-Motor Running"
Setup value	Content																																								
0	Positional deviation																																								
<1>	Motor rotational speed																																								
2	Torque output																																								
3	Control mode																																								
4	I/O signal status																																								
5	Error factor/history																																								
6	Software version																																								
7	Alarm																																								
8	Regenerative load factor																																								
9	Over-load factor																																								
10	Inertia ratio																																								
11	Sum of feedback pulses																																								
12	Sum of command pulses																																								
13	External scale deviation																																								
14	Sum of external scale feedback pulses																																								
15	Motor automatic recognizing function																																								
16	Analog input value																																								
17	Factor of "No-Motor Running"																																								
02 *	Setup of control mode	0 – 6 <1>	<p>You can set up the control mode to be used.</p> <table border="1"> <thead> <tr> <th rowspan="2">Setup value</th> <th colspan="2">Control mode</th> </tr> <tr> <th>1st mode</th> <th>2nd mode</th> </tr> </thead> <tbody> <tr><td>0</td><td>Position</td><td>–</td></tr> <tr><td><1></td><td>Velocity</td><td>–</td></tr> <tr><td>2</td><td>Torque</td><td>–</td></tr> <tr><td>3**1</td><td>Position</td><td>Velocity</td></tr> <tr><td>4**1</td><td>Position</td><td>Torque</td></tr> <tr><td>5**1</td><td>Velocity</td><td>Torque</td></tr> <tr><td>6</td><td>Full-closed</td><td>–</td></tr> </tbody> </table> <p>**1) When you set up the combination mode of 3, 4 or 5, you can select either the 1st or the 2nd with control mode switching input (C-MODE). When C-MODE is open, the 1st mode will be selected. When C-MODE is shorted, the 2nd mode will be selected. Don't enter commands 10ms before/after switching.</p> 	Setup value	Control mode		1st mode	2nd mode	0	Position	–	<1>	Velocity	–	2	Torque	–	3**1	Position	Velocity	4**1	Position	Torque	5**1	Velocity	Torque	6	Full-closed	–												
Setup value	Control mode																																								
	1st mode	2nd mode																																							
0	Position	–																																							
<1>	Velocity	–																																							
2	Torque	–																																							
3**1	Position	Velocity																																							
4**1	Position	Torque																																							
5**1	Velocity	Torque																																							
6	Full-closed	–																																							

<Notes>

- For parameters which No. have a suffix of "*", changed contents will be validated when you turn on the control power.

[Connection and Setup of Full-closed Control]

Standard default : < >

PrNo.	Title	Setup range	Function/Content																											
03	Selection of torque limit	0 – 3 <1>	<p>You can set up the torque limiting method for CCW/CW direction.</p> <table border="1"> <thead> <tr> <th>Setup value</th> <th>CCW</th> <th>CW</th> </tr> </thead> <tbody> <tr> <td>0</td> <td>X5 CCWTL : Pin-16</td> <td>X5 CWTL : Pin-18</td> </tr> <tr> <td><1></td> <td colspan="2">Pr5E is a limit value for both CCW and CW direction</td> </tr> <tr> <td>2</td> <td>Set with Pr5E</td> <td>Set with Pr5F</td> </tr> <tr> <td>3</td> <td colspan="2">When GAIN/TL-SEL input is open, set with Pr5E When GAIN/TL-SEL input is shorted, set with Pr5F</td> </tr> </tbody> </table> <p>When the setup value is 0, CCWTL and CWTL will be limited by Pr5E (1st torque limit setup). At the torque control, Pr5E becomes the limiting value for CCW/CW direction regardless of the setup of this parameter.</p>	Setup value	CCW	CW	0	X5 CCWTL : Pin-16	X5 CWTL : Pin-18	<1>	Pr5E is a limit value for both CCW and CW direction		2	Set with Pr5E	Set with Pr5F	3	When GAIN/TL-SEL input is open, set with Pr5E When GAIN/TL-SEL input is shorted, set with Pr5F													
Setup value	CCW	CW																												
0	X5 CCWTL : Pin-16	X5 CWTL : Pin-18																												
<1>	Pr5E is a limit value for both CCW and CW direction																													
2	Set with Pr5E	Set with Pr5F																												
3	When GAIN/TL-SEL input is open, set with Pr5E When GAIN/TL-SEL input is shorted, set with Pr5F																													
04 *	Setup of over-travel inhibit input	0 – 2 <1>	<p>In linear drive application, you can use this over-travel inhibiting function to inhibit the motor to run to the direction specified by limit switches which are installed at both ends of the axis, so that you can prevent the work load from damaging the machine due to the over-travel. With this input, you can set up the action of over-travel inhibit input.</p> <table border="1"> <thead> <tr> <th>Setup value</th> <th>CCWL/CWL input</th> <th>Input</th> <th>Connection to COM-</th> <th>Action</th> </tr> </thead> <tbody> <tr> <td rowspan="4">0</td> <td rowspan="4">Valid</td> <td rowspan="2">CCWL (CN X5,Pin-9)</td> <td>Close</td> <td>Normal status while CCW-side limit switch is not activated.</td> </tr> <tr> <td>Open</td> <td>Inhibits CCW direction, permits CW direction.</td> </tr> <tr> <td rowspan="2">CWL (CN X5,Pin-9)</td> <td>Close</td> <td>Normal status while CW-side limit switch is not activated.</td> </tr> <tr> <td>Open</td> <td>Inhibits CW direction, CCW direction permitted.</td> </tr> <tr> <td><1></td> <td>Invalid</td> <td colspan="3">Both CCWL and CWL inputs will be ignored, and over-travel inhibit function will be invalidated.</td> </tr> <tr> <td>2</td> <td>Valid</td> <td colspan="3">Err38 (Over-travel inhibit input protection) is triggered when either one of the connection of CW or CCW inhibi</td> </tr> </tbody> </table> <p><Cautions></p> <ol style="list-style-type: none"> When Pr04 is set to 0 and over-travel inhibit input is entered, the motor decelerates and stops according to the preset sequence with Pr66 (Sequence at over-travel inhibition). For details, refer to the explanation of Pr66. When both of CCWL and CWL inputs are opened while Pr04 is set to 0, the driver trips with Err38 (Overtravel inhibit input error) judging that this is an error. When you turn off the limit switch on upper side of the work at vertical axis application, the work may repeat up/down movement because of the losing of upward torque. In this case, set up Pr66 to 2, or limit with the host controller instead of using this function. 	Setup value	CCWL/CWL input	Input	Connection to COM-	Action	0	Valid	CCWL (CN X5,Pin-9)	Close	Normal status while CCW-side limit switch is not activated.	Open	Inhibits CCW direction, permits CW direction.	CWL (CN X5,Pin-9)	Close	Normal status while CW-side limit switch is not activated.	Open	Inhibits CW direction, CCW direction permitted.	<1>	Invalid	Both CCWL and CWL inputs will be ignored, and over-travel inhibit function will be invalidated.			2	Valid	Err38 (Over-travel inhibit input protection) is triggered when either one of the connection of CW or CCW inhibi		
Setup value	CCWL/CWL input	Input	Connection to COM-	Action																										
0	Valid	CCWL (CN X5,Pin-9)	Close	Normal status while CCW-side limit switch is not activated.																										
			Open	Inhibits CCW direction, permits CW direction.																										
		CWL (CN X5,Pin-9)	Close	Normal status while CW-side limit switch is not activated.																										
			Open	Inhibits CW direction, CCW direction permitted.																										
<1>	Invalid	Both CCWL and CWL inputs will be ignored, and over-travel inhibit function will be invalidated.																												
2	Valid	Err38 (Over-travel inhibit input protection) is triggered when either one of the connection of CW or CCW inhibi																												
07	Selection of speed monitor (SP)	0 – 9 <3>	<p>You can set up the content of analog speed monitor signal output (SP : CN X5, Pin43) and the relation between the output voltage level and the speed.</p> <table border="1"> <thead> <tr> <th>Setup value</th> <th>Signal of SP</th> <th>Relation between the output voltage level and the speed</th> </tr> </thead> <tbody> <tr> <td>0</td> <td rowspan="5">Motor actual speed</td> <td>6V / 47 r/min</td> </tr> <tr> <td>1</td> <td>6V / 188 r/min</td> </tr> <tr> <td>2</td> <td>6V / 750 r/min</td> </tr> <tr> <td><3></td> <td>6V / 3000 r/min</td> </tr> <tr> <td>4</td> <td>1.5V / 3000 r/min</td> </tr> <tr> <td>5</td> <td rowspan="5">Command speed</td> <td>6V / 47 r/min</td> </tr> <tr> <td>6</td> <td>6V / 188 r/min</td> </tr> <tr> <td>7</td> <td>6V / 750 r/min</td> </tr> <tr> <td>8</td> <td>6V / 3000 r/min</td> </tr> <tr> <td>9</td> <td>1.5V / 3000 r/min</td> </tr> </tbody> </table>	Setup value	Signal of SP	Relation between the output voltage level and the speed	0	Motor actual speed	6V / 47 r/min	1	6V / 188 r/min	2	6V / 750 r/min	<3>	6V / 3000 r/min	4	1.5V / 3000 r/min	5	Command speed	6V / 47 r/min	6	6V / 188 r/min	7	6V / 750 r/min	8	6V / 3000 r/min	9	1.5V / 3000 r/min		
Setup value	Signal of SP	Relation between the output voltage level and the speed																												
0	Motor actual speed	6V / 47 r/min																												
1		6V / 188 r/min																												
2		6V / 750 r/min																												
<3>		6V / 3000 r/min																												
4		1.5V / 3000 r/min																												
5	Command speed	6V / 47 r/min																												
6		6V / 188 r/min																												
7		6V / 750 r/min																												
8		6V / 3000 r/min																												
9		1.5V / 3000 r/min																												

Parameter Setup

Standard default : < >

PrNo.	Title	Setup range	Function/Content																																	
08	Selection of torque monitor (IM)	0 – 12 <0>	<p>You can set up the content of the analog torque monitor of the signal output (IM : CN X5, Pin-42), and the relation between the output voltage level and torque or deviation pulse counts.</p> <table border="1"> <thead> <tr> <th>Setup value</th> <th>Signal of IM</th> <th>Relation between the output voltage level and torque or deviation pulse counts</th> </tr> </thead> <tbody> <tr> <td><0></td> <td>Torque command</td> <td>3V/rated (100%) torque</td> </tr> <tr> <td>1</td> <td rowspan="5">Position deviation</td> <td>3V / 31Pulse</td> </tr> <tr> <td>2</td> <td>3V / 125Pulse</td> </tr> <tr> <td>3</td> <td>3V / 500Pulse</td> </tr> <tr> <td>4</td> <td>3V / 2000Pulse</td> </tr> <tr> <td>5</td> <td>3V / 8000Pulse</td> </tr> <tr> <td>6</td> <td rowspan="5">Full-closed deviation</td> <td>3V / 31Pulse</td> </tr> <tr> <td>7</td> <td>3V / 125Pulse</td> </tr> <tr> <td>8</td> <td>3V / 500Pulse</td> </tr> <tr> <td>9</td> <td>3V / 2000Pulse</td> </tr> <tr> <td>10</td> <td>3V / 8000Pulse</td> </tr> <tr> <td>11</td> <td rowspan="2">Torque command</td> <td>3V / 200% torque</td> </tr> <tr> <td>12</td> <td>3V / 400% torque</td> </tr> </tbody> </table>	Setup value	Signal of IM	Relation between the output voltage level and torque or deviation pulse counts	<0>	Torque command	3V/rated (100%) torque	1	Position deviation	3V / 31Pulse	2	3V / 125Pulse	3	3V / 500Pulse	4	3V / 2000Pulse	5	3V / 8000Pulse	6	Full-closed deviation	3V / 31Pulse	7	3V / 125Pulse	8	3V / 500Pulse	9	3V / 2000Pulse	10	3V / 8000Pulse	11	Torque command	3V / 200% torque	12	3V / 400% torque
Setup value	Signal of IM	Relation between the output voltage level and torque or deviation pulse counts																																		
<0>	Torque command	3V/rated (100%) torque																																		
1	Position deviation	3V / 31Pulse																																		
2		3V / 125Pulse																																		
3		3V / 500Pulse																																		
4		3V / 2000Pulse																																		
5		3V / 8000Pulse																																		
6	Full-closed deviation	3V / 31Pulse																																		
7		3V / 125Pulse																																		
8		3V / 500Pulse																																		
9		3V / 2000Pulse																																		
10		3V / 8000Pulse																																		
11	Torque command	3V / 200% torque																																		
12		3V / 400% torque																																		
09	Selection of TLC output	0 – 8 <0>	<p>You can assign the function of the torque in-limit output (TLC : CN X5 Pin-40).</p> <table border="1"> <thead> <tr> <th>Setup value</th> <th>Function</th> <th>Note</th> </tr> </thead> <tbody> <tr> <td><0></td> <td>Torque in-limit output</td> <td rowspan="8">For details of function of each output of the left, refer to the table of P.201, "Selection of TCL and ZSP outputs".</td> </tr> <tr> <td>1</td> <td>Zero speed detection output</td> </tr> <tr> <td>2</td> <td>Alarm output of either one of Over-regeneration /Over-load/Absolute battery/Fan lock/External scale</td> </tr> <tr> <td>3</td> <td>Over-regeneration alarm trigger output</td> </tr> <tr> <td>4</td> <td>Overload alarm output</td> </tr> <tr> <td>5</td> <td>Absolute battery alarm output</td> </tr> <tr> <td>6</td> <td>Fan lock alarm output</td> </tr> <tr> <td>7</td> <td>External scale alarm output</td> </tr> <tr> <td>8</td> <td>In-speed (Speed coincidence) output</td> </tr> </tbody> </table>	Setup value	Function	Note	<0>	Torque in-limit output	For details of function of each output of the left, refer to the table of P.201, "Selection of TCL and ZSP outputs".	1	Zero speed detection output	2	Alarm output of either one of Over-regeneration /Over-load/Absolute battery/Fan lock/External scale	3	Over-regeneration alarm trigger output	4	Overload alarm output	5	Absolute battery alarm output	6	Fan lock alarm output	7	External scale alarm output	8	In-speed (Speed coincidence) output											
Setup value	Function	Note																																		
<0>	Torque in-limit output	For details of function of each output of the left, refer to the table of P.201, "Selection of TCL and ZSP outputs".																																		
1	Zero speed detection output																																			
2	Alarm output of either one of Over-regeneration /Over-load/Absolute battery/Fan lock/External scale																																			
3	Over-regeneration alarm trigger output																																			
4	Overload alarm output																																			
5	Absolute battery alarm output																																			
6	Fan lock alarm output																																			
7	External scale alarm output																																			
8	In-speed (Speed coincidence) output																																			
0A	Selection of ZSP output	0 – 8 <1>	<p>You can assign the function of the zero speed detection output (ZSP: CN X5 Pin-12).</p> <table border="1"> <thead> <tr> <th>Setup value</th> <th>Function</th> <th>Note</th> </tr> </thead> <tbody> <tr> <td>0</td> <td>Torque in-limit output</td> <td rowspan="8">For details of function of each output of the left, refer to the table of P.201, "Selection of TCL and ZSP outputs".</td> </tr> <tr> <td><1></td> <td>Zero speed detection output</td> </tr> <tr> <td>2</td> <td>Alarm output of either one of Over-regeneration /Over-load/Absolute battery/Fan lock/External scale</td> </tr> <tr> <td>3</td> <td>Over-regeneration alarm trigger output</td> </tr> <tr> <td>4</td> <td>Overload alarm output</td> </tr> <tr> <td>5</td> <td>Absolute battery alarm output</td> </tr> <tr> <td>6</td> <td>Fan lock alarm output</td> </tr> <tr> <td>7</td> <td>External scale alarm output</td> </tr> <tr> <td>8</td> <td>In-speed (Speed coincidence) output</td> </tr> </tbody> </table>	Setup value	Function	Note	0	Torque in-limit output	For details of function of each output of the left, refer to the table of P.201, "Selection of TCL and ZSP outputs".	<1>	Zero speed detection output	2	Alarm output of either one of Over-regeneration /Over-load/Absolute battery/Fan lock/External scale	3	Over-regeneration alarm trigger output	4	Overload alarm output	5	Absolute battery alarm output	6	Fan lock alarm output	7	External scale alarm output	8	In-speed (Speed coincidence) output											
Setup value	Function	Note																																		
0	Torque in-limit output	For details of function of each output of the left, refer to the table of P.201, "Selection of TCL and ZSP outputs".																																		
<1>	Zero speed detection output																																			
2	Alarm output of either one of Over-regeneration /Over-load/Absolute battery/Fan lock/External scale																																			
3	Over-regeneration alarm trigger output																																			
4	Overload alarm output																																			
5	Absolute battery alarm output																																			
6	Fan lock alarm output																																			
7	External scale alarm output																																			
8	In-speed (Speed coincidence) output																																			
0B *	Setup of absolute encoder	0 – 2 <1>	<p>You can set up the using method of 17-bit absolute encoder.</p> <table border="1"> <thead> <tr> <th>Setup value</th> <th>Content</th> </tr> </thead> <tbody> <tr> <td>0</td> <td>Use as an absolute encoder.</td> </tr> <tr> <td><1></td> <td>Use as an incremental encoder.</td> </tr> <tr> <td>2</td> <td>Use as an absolute encoder, but ignore the multi-turn counter over.</td> </tr> </tbody> </table> <p><Caution> This parameter will be invalidated when 5-wire, 2500P/r incremental encoder is used.</p>	Setup value	Content	0	Use as an absolute encoder.	<1>	Use as an incremental encoder.	2	Use as an absolute encoder, but ignore the multi-turn counter over.																									
Setup value	Content																																			
0	Use as an absolute encoder.																																			
<1>	Use as an incremental encoder.																																			
2	Use as an absolute encoder, but ignore the multi-turn counter over.																																			
0C *	Baud rate setup of RS232 communication	0 – 5 <2>	<p>You can set up the communication speed of RS232. • Error of baud rate is $\pm 0.5\%$.</p> <table border="1"> <thead> <tr> <th>Setup value</th> <th>Baud rate</th> <th>Setup value</th> <th>Baud rate</th> </tr> </thead> <tbody> <tr> <td>0</td> <td>2400bps</td> <td>3</td> <td>19200bps</td> </tr> <tr> <td>1</td> <td>4800bps</td> <td>4</td> <td>38400bps</td> </tr> <tr> <td><2></td> <td>9600bps</td> <td>5</td> <td>57600bps</td> </tr> </tbody> </table>	Setup value	Baud rate	Setup value	Baud rate	0	2400bps	3	19200bps	1	4800bps	4	38400bps	<2>	9600bps	5	57600bps																	
Setup value	Baud rate	Setup value	Baud rate																																	
0	2400bps	3	19200bps																																	
1	4800bps	4	38400bps																																	
<2>	9600bps	5	57600bps																																	

[Connection and Setup of Full-closed Control]

Standard default : < >

PrNo.	Title	Setup range	Function/Content																
0D *	Baud rate setup of RS485 communication	0 – 5 <2>	<p>You can set up the communication speed of RS485. • Error of baud rate is $\pm 0.5\%$.</p> <table border="1" style="width: 100%; border-collapse: collapse; margin-top: 5px;"> <thead> <tr> <th style="width: 25%;">Setup value</th> <th style="width: 25%;">Baud rate</th> <th style="width: 25%;">Setup value</th> <th style="width: 25%;">Baud rate</th> </tr> </thead> <tbody> <tr> <td style="text-align: center;">0</td> <td style="text-align: center;">2400bps</td> <td style="text-align: center;">3</td> <td style="text-align: center;">19200bps</td> </tr> <tr> <td style="text-align: center;">1</td> <td style="text-align: center;">4800bps</td> <td style="text-align: center;">4</td> <td style="text-align: center;">38400bps</td> </tr> <tr> <td style="text-align: center;"><2></td> <td style="text-align: center;">9600bps</td> <td style="text-align: center;">5</td> <td style="text-align: center;">57600bps</td> </tr> </tbody> </table>	Setup value	Baud rate	Setup value	Baud rate	0	2400bps	3	19200bps	1	4800bps	4	38400bps	<2>	9600bps	5	57600bps
Setup value	Baud rate	Setup value	Baud rate																
0	2400bps	3	19200bps																
1	4800bps	4	38400bps																
<2>	9600bps	5	57600bps																
0E *	Setup of front panel lock	0 – 1 <0>	<p>You can limit the operation of the front panel to the monitor mode only. You can prevent such a misoperation as unexpected parameter change.</p> <p><Note> You can still change parameters via communication even though this setup is 1. To return this parameter to 0, use the console or the "PANATERM®".</p> <table border="1" style="width: 100%; border-collapse: collapse; margin-top: 5px;"> <thead> <tr> <th style="width: 30%;">Setup value</th> <th style="width: 70%;">Content</th> </tr> </thead> <tbody> <tr> <td style="text-align: center;"><0></td> <td style="text-align: center;">Valid to all</td> </tr> <tr> <td style="text-align: center;">1</td> <td style="text-align: center;">Monitor mode only</td> </tr> </tbody> </table>	Setup value	Content	<0>	Valid to all	1	Monitor mode only										
Setup value	Content																		
<0>	Valid to all																		
1	Monitor mode only																		

Parameters for Adjustment of Time Constants of Gains and Filters

Standard default : < >

PrNo.	Title	Setup range	Unit	Function/Content
10	1st gain of position loop	0 – 3000 A-C-frame:<63>* D-F-frame:<63>*	1/s	You can determine the response of the positional control system. Higher the gain of position loop you set, faster the positioning time you can obtain. Note that too high setup may cause oscillation.
11	1st gain of velocity loop	1 – 3500 A-C-frame:<35>* D-F-frame:<18>*	Hz	<p>You can determine the response of the velocity loop. In order to increase the response of overall servo system by setting high position loop gain, you need higher setup of this velocity loop gain as well. However, too high setup may cause oscillation.</p> <p><Caution> When the inertia ratio of Pr20 is set correctly, the setup unit of Pr11 becomes (Hz).</p>
12	1st time constant of velocity loop integration	1 – 1000 A-C-frame:<16>* D-F-frame:<31>*	ms	<p>You can set up the integration time constant of velocity loop. Smaller the setup, faster you can dog-in deviation at stall to 0. The integration will be maintained by setting to "999". The integration effect will be lost by setting to "1000".</p>
13	1st filter of speed detection	0 – 5 <0>*	–	<p>You can set up the time constant of the low pass filter (LPF) after the speed detection, in 6 steps. Higher the setup, larger the time constant you can obtain so that you can decrease the motor noise, however, response becomes slow. Use with a default value of 0 in normal operation.</p>
14	1st time constant of torque filter	0 – 2500 A-C-frame:<65>* D-F-frame:<126>*	0.01ms	You can set up the time constant of the 1st delay filter inserted in the torque command portion. You might expect suppression of oscillation caused by distortion resonance.
15	Velocity feed forward	–2000 – 2000 <300>*	0.1%	<p>You can set up the velocity feed forward volume at position control. Higher the setup, smaller positional deviation and better response you can obtain, however this might cause an overshoot.</p>
16	Time constant of feed forward filter	0 – 6400 <50>*	0.01ms	<p>You can set up the time constant of 1st delay filter inserted in velocity feed forward portion. You might expect to improve the overshoot or noise caused by larger setup of above velocity feed forward.</p>

<Notes>

- For parameters which No. have a suffix of "*", changed contents will be validated when you turn on the control power.
- Parameters which default values have a suffix of "*" will be automatically set up during real time auto-gain tuning. When you change manually, invalidate the real-time auto-gain tuning first then set, referring to P.239, "Release of Automatic Gain Adjusting Function" of Adjustment.

Parameter Setup

Standard default : < >

PrNo.	Title	Setup range	Unit	Function/Content
18	2nd gain of position loop	0 – 3000 A-C-frame:<73>* D-F-frame:<38>*	1/s	Position loop, velocity loop, speed detection filter and torque command filter have their 2 pairs of gain or time constant (1st and 2nd). For details of switching the 1st and the 2nd gain or the time constant, refer to P.226, "Adjustment". The function and the content of each parameter is as same as that of the 1st gain and time constant.
19	2nd gain of velocity loop	1 – 3500 A-C-frame:<35>* D-F-frame:<18>*	Hz	
1A	2nd time constant of velocity loop integration	1 – 1000 <1000>*	ms	
1B	1st filter of speed detection	0 – 5 <0>*	–	
1C	2nd filter of velocity detection	0 – 2500 A-C-frame:<65>* D-F-frame:<126>*	0.01ms	
1D	2nd time constant of torque filter	100 – 1500 <1500>	Hz	You can set up the frequency of the 1st resonance suppressing notch filter. The notch filter function will be invalidated by setting up this parameter to "1500".
1E	1st notch frequency	0 – 4 <2>	–	You can set up the notch filter width of the 1st resonance suppressing filter in 5 steps. Higher the setup, larger the notch width you can obtain. Use with default setup in normal operation.

Parameters for Auto-Gain Tuning

Standard default : < >

PrNo.	Title	Setup range	Unit	Function/Content																							
20	Inertia ratio	0 – 10000 <250>*	%	<p>You can set up the ratio of the load inertia against the rotor (of the motor) inertia.</p> <div style="border: 1px solid black; padding: 5px; width: fit-content; margin: 10px auto;"> $Pr20 = (\text{load inertia} / \text{rotor inertia}) \times 100 [\%]$ </div> <p>When you execute the normal auto-gain tuning, the load inertial will be automatically estimated after the preset action, and this result will be reflected in this parameter. The inertia ratio will be estimated at all time while the real-time auto-gain tuning is valid, and its result will be saved to EEPROM every 30 min.</p> <p><Caution> If the inertia ratio is correctly set, the setup unit of Pr11 and Pr19 becomes (Hz). When the inertia ratio of Pr20 is larger than the actual, the setup unit of the velocity loop gain becomes larger, and when the inertia ratio of Pr is smaller than the actual, the setup unit of the velocity loop gain becomes smaller.</p>																							
21	Setup of real-time auto-gain tuning	0 – 7 <1>	–	<p>You can set up the action mode of the real-time auto-gain tuning. With higher setup such as 3 or 6, the driver respond quickly to the change of the inertia during operation, however it might cause an unstable operation. Use 1 or 4 for normal operation. For the vertical axis application, use with the setup of 4 to 6. When vibration occurs at gain switching, set up this to "7".</p> <table border="1" style="width: 100%; border-collapse: collapse;"> <thead> <tr> <th>Setup value</th> <th>Real-time auto-gain tuning</th> <th>Varying degree of load inertia in motion</th> </tr> </thead> <tbody> <tr> <td>0</td> <td>Invalid</td> <td>–</td> </tr> <tr> <td><1></td> <td rowspan="3">Normal mode</td> <td>Little change</td> </tr> <tr> <td>2</td> <td>Gradual change</td> </tr> <tr> <td>3</td> <td>Rapid change</td> </tr> <tr> <td>4</td> <td rowspan="3">Vertical axis mode</td> <td>Little change</td> </tr> <tr> <td>5</td> <td>Gradual change</td> </tr> <tr> <td>6</td> <td>Rapid change</td> </tr> <tr> <td>7</td> <td>No gain switching</td> <td>Little change</td> </tr> </tbody> </table>	Setup value	Real-time auto-gain tuning	Varying degree of load inertia in motion	0	Invalid	–	<1>	Normal mode	Little change	2	Gradual change	3	Rapid change	4	Vertical axis mode	Little change	5	Gradual change	6	Rapid change	7	No gain switching	Little change
Setup value	Real-time auto-gain tuning	Varying degree of load inertia in motion																									
0	Invalid	–																									
<1>	Normal mode	Little change																									
2		Gradual change																									
3		Rapid change																									
4	Vertical axis mode	Little change																									
5		Gradual change																									
6		Rapid change																									
7	No gain switching	Little change																									

[Connection and Setup of Full-closed Control]

Standard default : <>

PrNo.	Title	Setup range	Unit	Function/Content																						
22	Selection of machine stiffness at real-time auto-gain tuning	0 – 15 A–C-frame: <4> D–F-frame: <1>	–	<p>You can set up the machine stiffness in 16 steps while the real-time auto-gain tuning is valid.</p> <table border="1" style="margin-left: auto; margin-right: auto;"> <tr> <td></td> <td>low ← machine stiffness → high</td> </tr> <tr> <td></td> <td>low ← servo gain → high</td> </tr> <tr> <td style="text-align: center;">Pr22</td> <td style="text-align: center;">0, 1-----14, 15</td> </tr> <tr> <td></td> <td>low ← response → high</td> </tr> </table> <p><Caution> When you change the setup value rapidly, the gain changes rapidly as well, and this may give impact to the machine. Increase the setup gradually watching the movement of the machine.</p>		low ← machine stiffness → high		low ← servo gain → high	Pr22	0, 1-----14, 15		low ← response → high														
	low ← machine stiffness → high																									
	low ← servo gain → high																									
Pr22	0, 1-----14, 15																									
	low ← response → high																									
23	Setup of adaptive filter mode	0 – 2 <1>	–	<p>You can set up the action of the adaptive filter.</p> <p>0 : Invalid 1 : Valid 2 : Hold (holds the adaptive filter frequency when this setup is changed to 2.)</p> <p><Caution> When you set up the adaptive filter to invalid, the adaptive filter frequency of Pr2F will be reset to 0. The adaptive filter is always invalid at the torque control mode.</p>																						
24	Selection of damping filter switching	0 – 2 <0>	–	<p>You can select the switching method when you use the damping filter.</p> <p>0 : No switching (both of 1st and 2nd are valid.) 1 : You can select either 1st or 2nd with damping control switching input (VS-SEL). when VS-SEL is opened, 1st damping filter selection (Pr2B, 2C) when VS-SEL is close, 2nd damping filter selection (Pr2D, 2E) 2 : You can switch with the position command direction. CCW : 1st damping filter selection (Pr2B, 2C). CW : 2nd damping filter selection (Pr2D, 2E).</p>																						
25	Setup of an action at normal mode auto-gain tuning	0 – 7 <0>	–	<p>You can set up the action pattern at the normal mode auto-gain tuning.</p> <table border="1" style="margin-left: auto; margin-right: auto;"> <thead> <tr> <th>Setup value</th> <th>Number of revolution</th> <th>Rotational direction</th> </tr> </thead> <tbody> <tr> <td><0></td> <td></td> <td>CCW → CW</td> </tr> <tr> <td>1</td> <td rowspan="3">2 [revolution]</td> <td>CW → CCW</td> </tr> <tr> <td>2</td> <td>CCW → CCW</td> </tr> <tr> <td>3</td> <td>CW → CW</td> </tr> <tr> <td>4</td> <td rowspan="4">1 [revolution]</td> <td>CCW → CW</td> </tr> <tr> <td>5</td> <td>CW → CCW</td> </tr> <tr> <td>6</td> <td>CCW → CCW</td> </tr> <tr> <td>7</td> <td>CW → CW</td> </tr> </tbody> </table> <p>e.g.) When the setup is 0, the motor turns 2 revolutions to CCW and 2 revolutions to CW.</p>	Setup value	Number of revolution	Rotational direction	<0>		CCW → CW	1	2 [revolution]	CW → CCW	2	CCW → CCW	3	CW → CW	4	1 [revolution]	CCW → CW	5	CW → CCW	6	CCW → CCW	7	CW → CW
Setup value	Number of revolution	Rotational direction																								
<0>		CCW → CW																								
1	2 [revolution]	CW → CCW																								
2		CCW → CCW																								
3		CW → CW																								
4	1 [revolution]	CCW → CW																								
5		CW → CCW																								
6		CCW → CCW																								
7		CW → CW																								
26	Setup of software limit	0 – 1000 <10>	0.1 revolution	<p>You can set up the movable range of the motor against the position command input range. When the motor movement exceeds the setup value, software limit protection of Pr34 will be triggered. This parameter is invalid with setup value of 0.</p>																						
28	2nd notch frequency	100 – 1500 <1500>	Hz	<p>You can set up the 2nd notch width of the resonance suppressing filter in 5 steps. The notch filter function is invalidated by setting up this parameter to "1500".</p>																						
29	Selection of 2nd notch width	0 – 4 <2>	–	<p>You can set up the notch width of 2nd resonance suppressing filter in 5 steps. Higher the setup, larger the notch width you can obtain. Use with default setup in normal operation.</p>																						
2A	Selection of 2nd notch depth	0 – 99 <0>	–	<p>You can set up the 2nd notch depth of the resonance suppressing filter. Higher the setup, shallower the notch depth and smaller the phase delay you can obtain.</p>																						

<Notes>

- Parameters which default values have a suffix of "*" will be automatically set up during real time auto-gain tuning. When you change manually, invalidate the real-time auto-gain tuning first then set, referring to P.239, "Release of Automatic Gain Adjusting Function" of Adjustment.

Parameter Setup

Standard default : < >

PrNo.	Title	Setup range	Unit	Function/Content
2B	1st damping frequency	0 – 2000 <0>	0.1Hz	You can set up the 1st damping frequency of the damping control which suppress vibration at the load edge. The driver measures vibration at load edge. Setup unit is 0.1[Hz]. The setup frequency is 10.0-200.0[Hz]. Setup of 0 – 99 becomes invalid. Refer to P.250, "Damping control" as well before using this parameter.
2C	Setup of 1st damping filter	-200 – 2000 <0>	0.1Hz	While you set up Pr2B (1st damping frequency), set this up to smaller value when torque saturation occurs, and to larger value when you need faster action. Use with the setup of 0 in normal operation. Refer to P.250, "Damping control" of Adjustment. <Caution> Setup is also limited by 10.0[Hz]–Pr2B<Pr2C<Pr2B
2D	2nd damping frequency	0 – 2000 <0>	0.1Hz	You can set up the 2nd damping frequency of the damping control which suppress vibration at the load edge. The driver measures vibration at the load edge. Setup unit is 0.1 [Hz]. Setup frequency is 10.0-200.0 [Hz]. Setup of 0-99 becomes invalid. Refer to P.250, "Damping control" of Adjustment as well before using this parameter.
2E	Setup of 2nd damping filter	-200 – 2000 <0>	0.1Hz	While you set up Pr2D (2nd damping frequency), set this up to smaller value when torque saturation occurs, and to larger value when you need faster action. Use with the setup of 0 in normal operation. Refer to P.250, "Damping control" of Adjustment. <Caution> Setup is also limited by 10.0[Hz]–Pr2B<Pr2C<Pr2B
2F	Adaptive filter frequency	0 – 64 <0>	–	Displays the table No. corresponding to the adaptive filter frequency. (Refer to P.234 of Adjustment.) This parameter will be automatically set and cannot be changed while the adaptive filter is valid. (when Pr23 (Setup of adaptive filter mode) is other than 0.) 0 – 4 Filter is invalid. 5 – 48 Filter is valid. 49 – 64 Filter validity changes according to Pr22. This parameter will be saved to EEPROM every 30 minutes while the adaptive filter is valid, and when the adaptive filter is valid at the next power-on, the adaptive action starts taking the saved data in EEPROM as an initial value. <Caution> When you need to clear this parameter to reset the adaptive action while the action is not normal, invalidate the adaptive filter (Pr23, "Setup of adaptive filter mode" to 0) once, then validate again. Refer to P.239, "Release of Automatic Gain Adjusting Function" of Adjustment as well.

Parameters for Adjustment (2nd Gain Switching Function)

Standard default : < >

PrNo.	Title	Setup range	Unit	Function/Content												
30	Setup of 2nd gain	0 – 1 <1>*	–	<p>You can select the PI/P action switching of the velocity control or 1st/2nd gain switching.</p> <table border="1"> <thead> <tr> <th>Setup value</th> <th>Gain selection/switching</th> </tr> </thead> <tbody> <tr> <td>0</td> <td>1st gain (PI/P switching enabled) *1</td> </tr> <tr> <td><1>*</td> <td>1st/2nd gain switching enabled *2</td> </tr> </tbody> </table> <p>*1 Switch the PI/P action with the gain switching input (GAIN CN X5, Pin-27). PI is fixed when Pr03 (Torque limit selection) is 3.</p> <table border="1"> <thead> <tr> <th>GAIN input</th> <th>Action of velocity loop</th> </tr> </thead> <tbody> <tr> <td>Open with COM–</td> <td>PI action</td> </tr> <tr> <td>Connect to COM–</td> <td>P action</td> </tr> </tbody> </table> <p>*2 For switching condition of the 1st and the 2nd, refer to P.243, "Gain Switching Function" of Adjustment.</p>	Setup value	Gain selection/switching	0	1st gain (PI/P switching enabled) *1	<1>*	1st/2nd gain switching enabled *2	GAIN input	Action of velocity loop	Open with COM–	PI action	Connect to COM–	P action
Setup value	Gain selection/switching															
0	1st gain (PI/P switching enabled) *1															
<1>*	1st/2nd gain switching enabled *2															
GAIN input	Action of velocity loop															
Open with COM–	PI action															
Connect to COM–	P action															

[Connection and Setup of Full-closed Control]

Standard default : < >

PrNo.	Title	Setup range	Unit	Function/Content
31	1st mode of control switching	0 – 10 <0>*	–	You can select the switching condition of 1st gain and 2nd gain while Pr30 is set to 1.
	Setup value	Gain switching condition		
	<0>*	Fixed to the 1st gain.		
	1	Fixed to 2nd gain.		
	2 *1	2nd gain selection when the gain switching input is turned on. (Pr30 setup must be 1.)		
	3 *2	2nd gain selection when the torque command variation is larger than the setups of Pr33 (1st level of control switching) and Pr34 (1st hysteresis of control switching).		
	4 *2	Fixed to the 1st gain.		
	5 *2	2nd gain selection when the command speed is larger than the setups of Pr33 (1st level of control switching) and Pr34 (1st hysteresis at control switching).		
	6 *2	2nd gain selection when the positional deviation is larger than the setups of Pr33 (1st control switching level) and Pr34 (1st hysteresis of control switching).		
	7 *2	2nd gain selection when more than one command pulse exist between 166μs.		
	8 *2	2nd gain selection when the positional deviation counter value exceeds the setup of Pr60 (Positioning completer range).		
	9 *2	2nd gain selection when the motor actual speed exceeds the setup of Pr33 (1st level of control switching) and Pr34 (1st hysteresis of control switching) .		
10 *2	Switches to the 2nd gain while the position command exists. Switches to the 1st gain when no-position command status lasts for the setup of Pr32 [x 166μs] and the speed falls slower than the setups of Pr33-34[r/min].			
				*1 Fixed to the 1st gain regardless of GAIN input, when Pr31 is set to 2 and Pr03 (Torque limit selection) is set to 3. *2 For the switching level and the timing, refer to P.243, "Gain Switching Function" of Adjustment.
32	1st delay time of control switching	0 – 10000 <30>*	x 166μs	You can set up the delay time when returning from the 2nd to the 1st gain, while Pr31 is set to 3 or 5-10.
33	1st level of control switching	0 – 20000 <50>*	–	You can set up the switching (judging) level of the 1st and the 2nd gains, while Pr31 is set to 3, 5, 6, 9 and 10. Unit varies depending on the setup of Pr31 (1st mode of control switching)
34	1st hysteresis of control switching	0 – 20000 <33>*	–	You can set up hysteresis width to be implemented above/below the judging level which is set up with Pr33. Unit varies depending on the setup of Pr31 (1st control switching mode). Definitions of Pr32 (Delay), Pr33 (Level) and Pr34 (Hysteresis) are explained in the fig. below. <Caution> The setup of Pr33 (Level) and Pr34 (Hysteresis) are valid as absolute values (positive/negative).

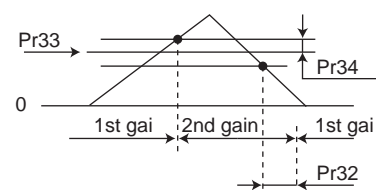

Full-Closed Control Mode

<Notes>

- For parameters which No. have a suffix of "*", changed contents will be validated when you turn on the control power.
- Parameters which default values have a suffix of "*" will be automatically set up during real time auto-gain tuning. When you change manually, invalidate the real-time auto-gain tuning first then set, referring to P.239, "Release of Automatic Gain Adjusting Function" of Adjustment.

Parameter Setup



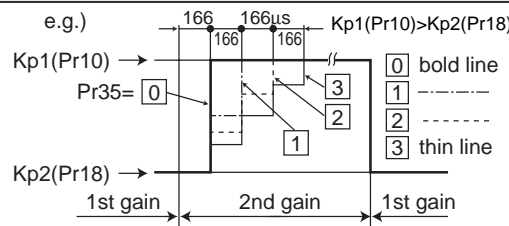

Standard default : < >

PrNo.	Title	Setup range	Unit	Function/Content
35	Switching time of position gain	0 – 10000 <20>* x 166μs	(setup value +1) x 166μs	<p>You can setup the step-by-step switching time to the position loop gain only at gain switching while the 1st and the 2nd gain switching is valid.</p> <p><Caution> The switching time is only valid when switching from small position gain to large position gain.</p> <p>e.g.) </p>
3D	JOG speed setup	0 – 500 <300>	r/min	You can setup the JOG speed. Refer to P.75, "Trial Run" of Preparation.

Parameters for Position Control

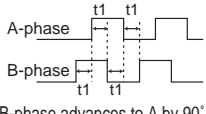
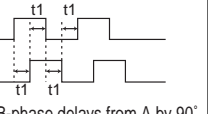
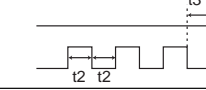
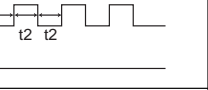
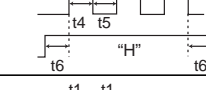
Standard default : < >

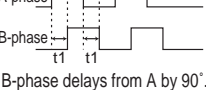
PrNo.	Title	Setup range	Function/Content
40*	Selection of command pulse input	0 – 1 <0>	You can select either the photo-coupler input or the exclusive input for line driver as the command pulse input.
	Setup value	Content	
	<0>	Photo-coupler input (X5 PULS1:Pin-3, PULS2:Pin-4, SIGN1:Pin-5, SIGN2:Pin-6)	
	1	Exclusive input for line driver (X5 PULSH1:Pin-44, PULSH2:Pin-45, SIGNH1:Pin-46, SIGNH2:Pin-47)	

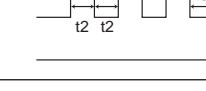
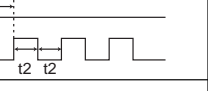
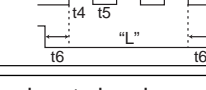
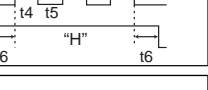
PrNo.	Title	Setup range	Function/Content						
			Pr41 setup value (Command pulse rotational direction setup)	Pr42 setup value (Command pulse input mode setup)	Command pulse format	Signal title	CCW command	CW command	
41*	Command pulse rotational direction setup	0 – 1 <0>	You can set up the rotational direction against the command pulse input, and the command pulse input format.						
42*	Setup of command pulse input mode	0 – 3 <1>	<0>	0 or 2	90° phase difference 2-phase pulse (A + B-phase)	PULS SIGN			
				<1>	CW pulse train + CCW pulse train	PULS SIGN			
				3	pulse train + Signal	PULS SIGN			
				1	0 or 2	90° phase difference 2-phase pulse (A + B-phase)	PULS SIGN		
					1	CW pulse train + CCW pulse train	PULS SIGN		
					3	pulse train + Signal	PULS SIGN		

• Permissible max. input frequency, and min. necessary time width of command pulse input signal.

Input I/F of PULS/SIGN signal	Permissible max. input frequency	Min. necessary time width					
		t ₁	t ₂	t ₃	t ₄	t ₅	t ₆
Pulse train interface exclusive to line driver	2Mpps	500ns	250ns	250ns	250ns	250ns	250ns
Pulse train interface	Line driver interface	500kpps	2μs	1μs	1μs	1μs	1μs
	Open collector interface	200kpps	5μs	2.5μs	2.5μs	2.5μs	2.5μs

Make the rising/falling time of the command pulse input signal to 0.1μs or smaller.

<Notes>

- For parameters which No. have a suffix of "*", changed contents will be validated when you turn on the control power.

[Connection and Setup of Full-closed Control]

Standard default : <>

PrNo.	Title	Setup range	Function/Content						
43	Invalidation of command pulse inhibit input	0 – 1 <1>	<p>You can select either the validation or the invalidation of the command pulse inhibit input (INH : CN X5 Pin-33).</p> <table border="1"> <thead> <tr> <th>Setup value</th> <th>INH input</th> </tr> </thead> <tbody> <tr> <td>0</td> <td>Valid</td> </tr> <tr> <td><1></td> <td>Invalid</td> </tr> </tbody> </table> <p>Command pulse input will be inhibited by opening the connection of INH input to COM-. When you do not use INH input, set up Pr43 to 1 so that you may not need to connect INH (CN I/F Pin-33) and COM- (Pin-41) outside of the driver.</p>	Setup value	INH input	0	Valid	<1>	Invalid
Setup value	INH input								
0	Valid								
<1>	Invalid								
44 *	Numerator of pulse output division	1 – 32767 <2500>	<p>You can set up the pulse counts to be fed out from the pulse outputs (X5 OA+ : Pin-21, OA- : Pin-22, OB+ : Pin-48, OB- : Pin-49).</p> <ul style="list-style-type: none"> In case the external scale pulse is fed out (When the control mode is full-closed control and Pr46 (Reversal of pulse output logic) is 2 or 3.) Pr45 = 0 : No division will be executed. When Pr45 is other than 0, travel per one pulse will be divided with discrete ratio according to the formula below. $\text{Travel per one output pulse} = \frac{\text{Pr45 (Denominator of pulse output division)}}{\text{Pr44 (Numerator of pulse output division)}} \times \text{travel per one pulse of external scale}$ <p><Cautions></p> <ul style="list-style-type: none"> Travel per one pulse of the external scale is 0.05 [É m] for AT500 series, and 0.5 [É m] for ST771 series. Setup of Pr44 > Pr45 becomes invalid. (In this case, no division will be executed) Z-phase will be fed out synchronizing with A-phase when the work crosses the zero absolute position at first time after the control power is turned on. After this, Z-phase will be fed out at the intervals set with Pr47 (Z-phase setup of external scale). 						
45 *	Denominator of pulse output division	0 – 32767 <0>	<ul style="list-style-type: none"> In case the encoder pulse is fed out (When the control mode is position, velocity and torque control, and P446 (Reversal of pulse output logic) is 0 or 1.) You can set up the pulse counts to be fed out from the pulse output (X5 OA+ : Pin-21, OA- : Pin-22, OB+ : Pin-48, OB- : Pin-49). <table border="1"> <tr> <td> <ul style="list-style-type: none"> Pr45=<0> (Default) You can set up the output pulse counts per one motor revolution for each OA and OB with the Pr44 setup. Therefore the pulse output resolution after quadruple can be obtained from the formula below. $\text{The pulse output resolution per one revolution} = \text{Pr44 (Numerator of pulse output division)} \times 4$ </td> </tr> </table> <ul style="list-style-type: none"> Pr45≠0 : The pulse output resolution per one revolution can be divided by any ration according to the formula below. $\text{Pulse output resolution per one revolution} = \frac{\text{Pr44 (Numerator of pulse output division)}}{\text{Pr45 (Denominator of pulse output division)}} \times \text{Encoder resolution}$ <p><Cautions></p> <ul style="list-style-type: none"> The encoder resolution is 131072 [P/r] for the 17-bit absolute encoder, and 10000 [P/r] for the 5-wire 2500P/r incremental encoder. The pulse output resolution per one revolution cannot be greater than the encoder resolution. (In the above setup, the pulse output resolution equals to the encoder resolution.) Z-phase is fed out once per one revolution of the motor. When the pulse output resolution obtained from the above formula is multiple of 4, Z-phase synchronizes with A-phase. In other case, the Z-phase width equals to output with the encoder resolution, and becomes narrower than A-phase, hence does not synchronize with A-phase. <table border="1"> <tr> <td> <p>when encoder resolution x $\frac{\text{Pr44}}{\text{Pr45}}$ is multiple of 4</p> <p>Synchronized</p> </td> <td> <p>when encoder resolution x $\frac{\text{Pr44}}{\text{Pr45}}$ is not multiple of 4</p> <p>Not-synchronized</p> </td> </tr> </table>	<ul style="list-style-type: none"> Pr45=<0> (Default) You can set up the output pulse counts per one motor revolution for each OA and OB with the Pr44 setup. Therefore the pulse output resolution after quadruple can be obtained from the formula below. $\text{The pulse output resolution per one revolution} = \text{Pr44 (Numerator of pulse output division)} \times 4$ 	<p>when encoder resolution x $\frac{\text{Pr44}}{\text{Pr45}}$ is multiple of 4</p> <p>Synchronized</p>	<p>when encoder resolution x $\frac{\text{Pr44}}{\text{Pr45}}$ is not multiple of 4</p> <p>Not-synchronized</p>			
<ul style="list-style-type: none"> Pr45=<0> (Default) You can set up the output pulse counts per one motor revolution for each OA and OB with the Pr44 setup. Therefore the pulse output resolution after quadruple can be obtained from the formula below. $\text{The pulse output resolution per one revolution} = \text{Pr44 (Numerator of pulse output division)} \times 4$ 									
<p>when encoder resolution x $\frac{\text{Pr44}}{\text{Pr45}}$ is multiple of 4</p> <p>Synchronized</p>	<p>when encoder resolution x $\frac{\text{Pr44}}{\text{Pr45}}$ is not multiple of 4</p> <p>Not-synchronized</p>								

Parameter Setup

Standard default : < >

PrNo.	Title	Setup range	Function/Content																											
46 *	Reversal of pulse output logic	0 – 3 <0>	<p>You can set up the B-phase logic and the output source of the pulse output (X5 OB+ : Pin-48, OB- : Pin-49). With this parameter, you can reverse the phase relation between the A-phase pulse and the B-phase pulse by reversing the B-phase logic.</p> <table border="1"> <thead> <tr> <th>Setup value</th> <th>A-phase (OA)</th> <th>at motor CCW rotation</th> <th>at motor CW rotation</th> </tr> </thead> <tbody> <tr> <td><0>, 2</td> <td>B-phase(OB) non-reversal</td> <td></td> <td></td> </tr> <tr> <td>1, 3</td> <td>B-phase(OB) reversal</td> <td></td> <td></td> </tr> </tbody> </table> <table border="1"> <thead> <tr> <th>Pr46</th> <th>B-phase logic</th> <th>Output source</th> </tr> </thead> <tbody> <tr> <td><0></td> <td>Non-reversal</td> <td>Encoder position</td> </tr> <tr> <td>1</td> <td>Reversal</td> <td>Encoder position</td> </tr> <tr> <td>2 *1</td> <td>Non-reversal</td> <td>External scale position</td> </tr> <tr> <td>3 *1</td> <td>Reversal</td> <td>External scale position</td> </tr> </tbody> </table> <p>*1 The output source of Pr46=2, 3 is valid onlt at full-closed control.</p>	Setup value	A-phase (OA)	at motor CCW rotation	at motor CW rotation	<0>, 2	B-phase(OB) non-reversal			1, 3	B-phase(OB) reversal			Pr46	B-phase logic	Output source	<0>	Non-reversal	Encoder position	1	Reversal	Encoder position	2 *1	Non-reversal	External scale position	3 *1	Reversal	External scale position
Setup value	A-phase (OA)	at motor CCW rotation	at motor CW rotation																											
<0>, 2	B-phase(OB) non-reversal																													
1, 3	B-phase(OB) reversal																													
Pr46	B-phase logic	Output source																												
<0>	Non-reversal	Encoder position																												
1	Reversal	Encoder position																												
2 *1	Non-reversal	External scale position																												
3 *1	Reversal	External scale position																												
47 *	Z-phase setup of external scale	0 – 32767 <0>	<p>You can setup the interval of Z-phase output in the A-phase output pulses of the external scale (before quadruple), when you use the external scale as an output source for the pulse output. (Pr02, (Control mode setup) is 6 and Pr46 (Reversal of pulse output logic) is 2 or 3.)</p> <ul style="list-style-type: none"> when Pr47 = <0> (default), no Z-phase is fed out of the external scale. when Pr47 = 1-32767, Z-phase will be fed out synchronizing with A-phase when the work crosses the absolute position of 0 at first time after the control power on. After this, Z-phase will be fed out at the intervals set with this parameter. 																											
48	Electronic gear function-related (Pr48-4B)																													
	1st numerator of electronic gear	0 – 10000 <0>	<p>Electronic gear (Command pulse division/multilication) function</p> <ul style="list-style-type: none"> Purpose of this function <ol style="list-style-type: none"> You can set up any motor revolution and travel per input command unit. You can increase the nominal command pulse frequency when you cannot obtain the required speed due to the limit of pulse generator of the host controller. Block diagram of electronic gear <div style="text-align: center;"> </div> <ul style="list-style-type: none"> "Numerator" selection of electronic gear *1 : Select the 1st or the 2nd with the command electronic gear input switching (DIV : CN X5, Pin-28) <table border="1"> <tr> <td>DIV input open</td> <td>Selection of 1st numerator (Pr48)</td> </tr> <tr> <td>DIV input connect to COM-</td> <td>Selection of 2nd numerator (Pr49)</td> </tr> </table> <p>The electronic gear ratio is set with the formula below.</p> <ul style="list-style-type: none"> when the numerator is <0> (Default) : Numerator (Pr48,49)X2^{Pr4A} is automatically set equal to encoder resolution. $\text{Electronic gear ratio} = \frac{\text{Encoder resolution}}{\text{Command pulse counts per one revolution (Pr48)}}$ <ul style="list-style-type: none"> when numerator ≠ 0 : $\text{Electronic gear ratio} = \frac{\text{Numerator of command electronic gear (Pr48,49)} \times 2^{\text{Multiplier of command div/multipl numerator (Pr4A)}}}{\text{Denominator of command electronic gear (Pr4B)}}$ <p><Caution> In actual calculation of numerator (Pr48, Pr49) X2^{Pr4A}, 4194304 (Pr4D setup value +1) becomes the max. value.</p>	DIV input open	Selection of 1st numerator (Pr48)	DIV input connect to COM-	Selection of 2nd numerator (Pr49)																							
DIV input open	Selection of 1st numerator (Pr48)																													
DIV input connect to COM-	Selection of 2nd numerator (Pr49)																													
49	2nd numerator of electronic gear	0 – 10000 <0>																												
4A	Multiplier of electronic gear numerator	0 – 17 <0>																												
4B	Denominator of electronic gear	0 – 10000 <10000>																												

[Connection and Setup of Full-closed Control]

Standard default : < >

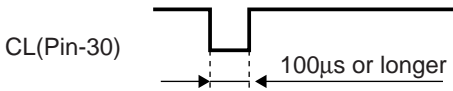
PrNo.	Title	Setup range	Function/Content										
4C	Setup of primary delay smoothing	0 – 7 <1>	<p>Smoothing filter is the filter for primary delay which is inserted after the electronic gear.</p> <div style="border: 1px solid black; padding: 5px;"> <p>Purpose of smoothing filter</p> <ul style="list-style-type: none"> • Reduce the step motion of the motor while the command pulse is rough. • Actual examples which cause rough command pulse are; <ol style="list-style-type: none"> (1) when you set up a high multiplier ratio (10 times or more). (2) when the command pulse frequency is low. </div> <p>You can set the time constant of the smoothing filter in 8 steps with Pr4C.</p> <table border="1" style="width: 100%;"> <thead> <tr> <th>Setup value</th> <th>Time constant</th> </tr> </thead> <tbody> <tr> <td>0</td> <td>No filter function</td> </tr> <tr> <td><1></td> <td>Time constant small</td> </tr> <tr> <td>↓</td> <td></td> </tr> <tr> <td>7</td> <td>Time constant large</td> </tr> </tbody> </table>	Setup value	Time constant	0	No filter function	<1>	Time constant small	↓		7	Time constant large
Setup value	Time constant												
0	No filter function												
<1>	Time constant small												
↓													
7	Time constant large												
4D *	Setup of FIR smoothing	0 – 31 <0>	<p>You can set up the moving average times of the FIR filter covering the command pulse. (Setup value + 1) become average travel times.</p>										
4E	Counter clear input mode	0 – 2 <1>	<p>You can set up the clearing conditions of the counter clear input signal which clears the deviation counter.</p> <table border="1" style="width: 100%;"> <thead> <tr> <th>Setup value</th> <th>Clearing condition</th> </tr> </thead> <tbody> <tr> <td>0</td> <td>Clears the deviation counter at level (shorting for longer than 100μs)*1</td> </tr> <tr> <td><1></td> <td>Clears the deviation counter at falling edge (open-shorting for longer than 100μs)*1</td> </tr> <tr> <td>2</td> <td>Invalid</td> </tr> </tbody> </table> <p>*1 : Min. time width of CL signal</p>  <p style="text-align: center;">CL (Pin-30) 100μs or longer</p>	Setup value	Clearing condition	0	Clears the deviation counter at level (shorting for longer than 100μs)*1	<1>	Clears the deviation counter at falling edge (open-shorting for longer than 100μs)*1	2	Invalid		
Setup value	Clearing condition												
0	Clears the deviation counter at level (shorting for longer than 100μs)*1												
<1>	Clears the deviation counter at falling edge (open-shorting for longer than 100μs)*1												
2	Invalid												

<Notes>

- For parameters which No. have a suffix of "*", changed contents will be validated when you turn on the control power.

Parameter Setup

Parameters for Velocity and Torque Control

Standard default : < >

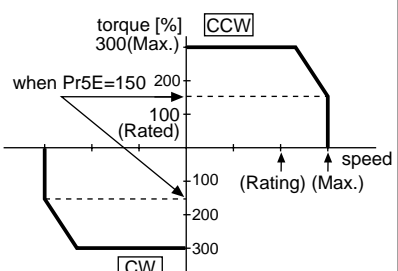
PrNo.	Title	Setup range	Unit	Function/Content
5E	1st torque limit setup	0 – 500 <500> *2	%	<p>You can set up the limit value of the motor output torque (Pr5E : 1st torque, Pr5F : 2nd torque). For the torque limit selection, refer to Pr03 (Torque limit selection).</p> <p>This torque limit function limits the max. motor torque inside of the driver with parameter setup. In normal operation, this driver permits approx. 3 times larger torque than the rated torque instantaneously. If this 3 times bigger torque causes any trouble to the load (machine) strength, you can use this function to limit the max. torque.</p> <ul style="list-style-type: none"> • Setup value is to be given in % against the rated torque. • Right fig. shows example of 150% setup with Pr03=1. • Pr5E limits the max. torque for both CCW and CW directions.  <p><Caution> You cannot set up a larger value to this parameter than the default setup value of "Max. output torque setup" of System parameter (which you cannot change through operation with PANATERM® or panel). Default value varies depending on the combination of the motor and the driver. For details, refer to P.57, "Setup of Torque Limit " of Preparation.</p>
5F	2nd torque limit setup	0 – 500 <500> *2	%	

<Note>

- For parameters which default. has a suffix of "*2", value varies depending on the combination of the driver and the motor.

Parameters for Sequence

Standard default : < >

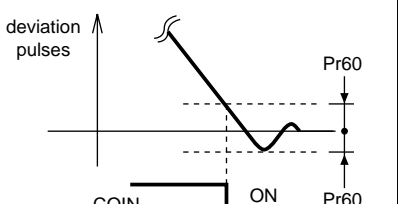
PrNo.	Title	Setup range	Unit	Function/Content
60	Positioning complete(In-position) range	0 – 32767 <131>	Pulse	<p>You can set up the timing to feed out the positioning complete signal (COIN : CN X5, Pin-39).</p> <p>The positioning complete signal (COIN) will be fed out when the deviation counter pulse counts fall within Δ(the setup value), after the command pulse entry is completed.</p> <p>The setup unit should be the encoder pulse counts at the position control and the external scale pulse counts at the full-closed control.</p> <ul style="list-style-type: none"> • Basic unit of deviation pulse is encoder "resolution", and varies per the encoder as below. <ul style="list-style-type: none"> (1) 17-bit encoder : $2^{17} = 131072$ (2) 2500P/r encoder : $4 \times 2500 = 10000$ <p><Cautions></p> <ol style="list-style-type: none"> 1. If you set up too small value to Pr60, the time until the COIN signal is fed might become longer, or cause chattering at output. 2. The setup of "Positioning complete range" does not give any effect to the final positioning accuracy. 

[Connection and Setup of Full-closed Control]

Standard default : <>

PrNo.	Title	Setup range	Unit	Function/Content																
61	Zero-speed	10 – 20000 <50>	r/min	<p>You can set up the timing to feed out the zero-speed detection output signal (ZSP : CN X5, Pin-12 or TCL : CN X5, Pin-40) in rotational speed [r/min]. The zero-speed detection signal (ZSP) will be fed out when the motor speed falls below the setup of this parameter, Pr61. In-speed (Speed coincidence) signal (V-COIN) will be fed out when the difference between the speed command and the motor speed falls below the setup of this parameter, Pr61.</p> <ul style="list-style-type: none"> • The setup of P61 is valid for both CCW and CW direction regardless of the motor rotating direction. • There is hysteresis of 10 [r/min]. 																
63	Setup of positioning complete (In-position) output	0 – 3 <0>	–	<p>You can set up the action of the positioning complete signal (COIN : Pin-39 of CN X5) in combination with Pr60 (Positioning complete range).</p> <table border="1"> <thead> <tr> <th>Setup value</th> <th>Action of positioning complete signal</th> </tr> </thead> <tbody> <tr> <td><0></td> <td>The signal will turn on when the positional deviation is smaller than Pr60 (Positioning complete range)</td> </tr> <tr> <td>1</td> <td>The signal will turn on when there is no position command and the positional deviation is smaller than Pr60 (Positioning complete range).</td> </tr> <tr> <td>2</td> <td>The signal will turn on when there is no position command, the zero-speed detection signal is ON and the positional deviation is smaller than Pr60 (Positioning complete range).</td> </tr> <tr> <td>3</td> <td>The signal will turn on when there is no position command and the positional deviation is smaller than Pr60 (Positioning complete range). Then holds "ON" status until the next position command is entered.</td> </tr> </tbody> </table>	Setup value	Action of positioning complete signal	<0>	The signal will turn on when the positional deviation is smaller than Pr60 (Positioning complete range)	1	The signal will turn on when there is no position command and the positional deviation is smaller than Pr60 (Positioning complete range).	2	The signal will turn on when there is no position command, the zero-speed detection signal is ON and the positional deviation is smaller than Pr60 (Positioning complete range).	3	The signal will turn on when there is no position command and the positional deviation is smaller than Pr60 (Positioning complete range). Then holds "ON" status until the next position command is entered.						
Setup value	Action of positioning complete signal																			
<0>	The signal will turn on when the positional deviation is smaller than Pr60 (Positioning complete range)																			
1	The signal will turn on when there is no position command and the positional deviation is smaller than Pr60 (Positioning complete range).																			
2	The signal will turn on when there is no position command, the zero-speed detection signal is ON and the positional deviation is smaller than Pr60 (Positioning complete range).																			
3	The signal will turn on when there is no position command and the positional deviation is smaller than Pr60 (Positioning complete range). Then holds "ON" status until the next position command is entered.																			
65	LV trip selection at main power OFF	0 – 1 <1>	–	<p>You can select whether or not to activate Err13 (Main power under-voltage protection) function while the main power shutoff continues for the setup of Pr6D (Main power-OFF detection time).</p> <table border="1"> <thead> <tr> <th>Setup value</th> <th>Action of main power low voltage protection</th> </tr> </thead> <tbody> <tr> <td>0</td> <td>When the main power is shut off during Servo-ON, Err13 will not be triggered and the driver turns to Servo-OFF. The driver returns to Servo-ON again after the main power resumption.</td> </tr> <tr> <td><1></td> <td>When the main power is shut off during Servo-ON, the driver will trip due to Err13 (Main power low voltage protection).</td> </tr> </tbody> </table> <p><Caution> This parameter is invalid when Pr6D (Detection time of main power OFF)=1000. Err13 (Main power under-voltage protection) is triggered when setup of P66D is long and P-N voltage of the main converter falls below the specified value before detecting the main power shutoff, regardless of the Pr65 setup. Refer to P.42, "Timing Chart-At Power-ON" of Preparation as well.</p>	Setup value	Action of main power low voltage protection	0	When the main power is shut off during Servo-ON, Err13 will not be triggered and the driver turns to Servo-OFF. The driver returns to Servo-ON again after the main power resumption.	<1>	When the main power is shut off during Servo-ON, the driver will trip due to Err13 (Main power low voltage protection).										
Setup value	Action of main power low voltage protection																			
0	When the main power is shut off during Servo-ON, Err13 will not be triggered and the driver turns to Servo-OFF. The driver returns to Servo-ON again after the main power resumption.																			
<1>	When the main power is shut off during Servo-ON, the driver will trip due to Err13 (Main power low voltage protection).																			
66 *	Sequence at over-travel inhibit	0 – 2 <0>	–	<p>You can set up the running condition during deceleration or after stalling, while over-travel inhibit input (CCWL : Connector CN X5, Pin-9 or CWL : Connector CN X5, Pin-8) is valid</p> <table border="1"> <thead> <tr> <th>Setup value</th> <th>During deceleration</th> <th>After stalling</th> <th>Deviation counter content</th> </tr> </thead> <tbody> <tr> <td><0></td> <td>Dynamic brake action</td> <td>Torque command=0 towards inhibited direction</td> <td>Hold</td> </tr> <tr> <td>1</td> <td>Torque command=0 towards inhibited direction</td> <td>Torque command=0 towards inhibited direction</td> <td>Hold</td> </tr> <tr> <td>2</td> <td>Emergency stop</td> <td>Torque command=0 towards inhibited direction</td> <td>Clears before/ after deceleration</td> </tr> </tbody> </table> <p><Caution> In case of the setup value of 2, torque limit during deceleration will be limited by the setup value of Pr6E (Torque setup at emergency stop).</p>	Setup value	During deceleration	After stalling	Deviation counter content	<0>	Dynamic brake action	Torque command=0 towards inhibited direction	Hold	1	Torque command=0 towards inhibited direction	Torque command=0 towards inhibited direction	Hold	2	Emergency stop	Torque command=0 towards inhibited direction	Clears before/ after deceleration
Setup value	During deceleration	After stalling	Deviation counter content																	
<0>	Dynamic brake action	Torque command=0 towards inhibited direction	Hold																	
1	Torque command=0 towards inhibited direction	Torque command=0 towards inhibited direction	Hold																	
2	Emergency stop	Torque command=0 towards inhibited direction	Clears before/ after deceleration																	

<Notes>

- For parameters which No. have a suffix of "*", changed contents will be validated when you turn on the control power.

Parameter Setup

Standard default : < >

PrNo.	Title	Setup range	Unit	Function/Content																																														
67	Sequence at main power OFF	0 – 9 <0>	–	<p>When Pr65 (LV trip selection at main power OFF) is 0, you can set up,</p> <ol style="list-style-type: none"> 1) the action during deceleration and after stalling 2) the clearing of deviation counter content after the main power is shut off. <table border="1"> <thead> <tr> <th rowspan="2">Setup value</th> <th colspan="2">Action</th> <th rowspan="2">Deviation counter content</th> </tr> <tr> <th>During deceleration</th> <th>After stalling</th> </tr> </thead> <tbody> <tr> <td><0></td> <td>DB</td> <td>DB</td> <td>Clear</td> </tr> <tr> <td>1</td> <td>Free-run</td> <td>DB</td> <td>Clear</td> </tr> <tr> <td>2</td> <td>DB</td> <td>Free-run</td> <td>Clear</td> </tr> <tr> <td>3</td> <td>Free-run</td> <td>Free-run</td> <td>Clear</td> </tr> <tr> <td>4</td> <td>DB</td> <td>DB</td> <td>Hold</td> </tr> <tr> <td>5</td> <td>Free-run</td> <td>DB</td> <td>Hold</td> </tr> <tr> <td>6</td> <td>DB</td> <td>Free-run</td> <td>Hold</td> </tr> <tr> <td>7</td> <td>Free-run</td> <td>Free-run</td> <td>Hold</td> </tr> <tr> <td>8</td> <td>Emergency stop</td> <td>D</td> <td>Clear</td> </tr> <tr> <td>9</td> <td>Emergency stop</td> <td>Free-run</td> <td>Clear</td> </tr> </tbody> </table> <p>(DB: Dynamic Brake action) <Caution> In case of the setup value of 8 or 9, torque limit during deceleration will be limited by the setup value of Pr6E (Torque setup at emergency stop).</p>	Setup value	Action		Deviation counter content	During deceleration	After stalling	<0>	DB	DB	Clear	1	Free-run	DB	Clear	2	DB	Free-run	Clear	3	Free-run	Free-run	Clear	4	DB	DB	Hold	5	Free-run	DB	Hold	6	DB	Free-run	Hold	7	Free-run	Free-run	Hold	8	Emergency stop	D	Clear	9	Emergency stop	Free-run	Clear
Setup value	Action		Deviation counter content																																															
	During deceleration	After stalling																																																
<0>	DB	DB	Clear																																															
1	Free-run	DB	Clear																																															
2	DB	Free-run	Clear																																															
3	Free-run	Free-run	Clear																																															
4	DB	DB	Hold																																															
5	Free-run	DB	Hold																																															
6	DB	Free-run	Hold																																															
7	Free-run	Free-run	Hold																																															
8	Emergency stop	D	Clear																																															
9	Emergency stop	Free-run	Clear																																															
68	Sequence at alarm	0 – 3 <0>	–	<p>You can set up the action during deceleration or after stalling when some error occurs while either one of the protective functions of the driver is triggered.</p> <table border="1"> <thead> <tr> <th rowspan="2">Setup value</th> <th colspan="2">Action</th> <th rowspan="2">Deviation counter content</th> </tr> <tr> <th>During deceleration</th> <th>After stalling</th> </tr> </thead> <tbody> <tr> <td><0></td> <td>DB</td> <td>DB</td> <td>Hold</td> </tr> <tr> <td>1</td> <td>Free-run</td> <td>DB</td> <td>Hold</td> </tr> <tr> <td>2</td> <td>DB</td> <td>Free-run</td> <td>Hold</td> </tr> <tr> <td>3</td> <td>Free-run</td> <td>Free-run</td> <td>Hold</td> </tr> </tbody> </table> <p>(DB: Dynamic Brake action) <Caution> The content of the deviation counter will be cleared when clearing the alarm. Refer to P.43, "Timing Chart (When an error (alarm) occurs (at Servo-ON command status))" of Preparation.</p>	Setup value	Action		Deviation counter content	During deceleration	After stalling	<0>	DB	DB	Hold	1	Free-run	DB	Hold	2	DB	Free-run	Hold	3	Free-run	Free-run	Hold																								
Setup value	Action		Deviation counter content																																															
	During deceleration	After stalling																																																
<0>	DB	DB	Hold																																															
1	Free-run	DB	Hold																																															
2	DB	Free-run	Hold																																															
3	Free-run	Free-run	Hold																																															
69	Sequence at Servo-Off	0 – 9 <0>	–	<p>You can set up,</p> <ol style="list-style-type: none"> 1) the action during deceleration and after stalling 2) the clearing of deviation counter content, after turning to Servo-OFF (SRV-ON signal : CN X5, Pin-29 is turned from ON to OFF) <p>The relation between the setup value of Pr69 and the action/deviation counter clearance is same as that of Pr67 (Sequence at Main Power Off) Refer to P.44, "Timing Chart"-Servo-ON/OFF action while the motor is at stall" of Preparation as well.</p>																																														
6A	Setup of mechanical brake action at stall	0 – 100 <0>	2ms	<p>You can set up the time from when the brake release signal (BRK-OFF : CN X5, Pin-10 and 11) turns off to when the motor is de-energized (Servo-free), when the motor turns to Servo-OFF while the motor is at stall.</p> <div style="border: 1px solid black; padding: 5px;"> <ul style="list-style-type: none"> • Set up to prevent a micro-travel/ drop of the motor (work) due to the action delay time (tb) of the brake • After setting up $Pr6a \geq tb$, then compose the sequence so as the driver turns to Servo-OFF after the brake is actually activated. </div> <p>Refer to P.44, "Timing Chart"-Servo-ON/OFF Action While the Motor Is at Stall" of Preparation as well.</p>																																														

[Connection and Setup of Full-closed Control]

Standard default : < >

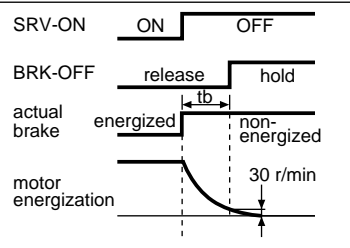
PrNo.	Title	Setup range	Unit	Function/Content															
6B	Setup of mechanical brake action at running	0 – 100 <0>	2ms	<p>You can set up time from when detecting the off of Servo-ON input signal (SRV-ON : CN X5, Pin-29) is to when external brake release signal (BRK-OFF : CN X5, Pin-10 and 11) turns off, while the motor turns to servo off during the motor in motion.</p> <div style="display: flex; align-items: flex-start;"> <ul style="list-style-type: none"> Set up to prevent the brake deterioration due to the motor running. At Servo-OFF during the motor is running, tb of the right fig. will be a shorter one of either Pr6B setup time, or time lapse till the motor speed falls below 30r/min.  </div> <p>Refer to P.45, "Timing Chart"-Servo-ON/OFF action while the motor is in motion" of Preparation as well.</p>															
6C *	Selection of external regenerative resistor	0 – 3 for A, B-frame <3> for B-F-frame <0>	–	<p>With this parameter, you can select either to use the built-in regenerative resistor of the driver, or to separate this built-in regenerative resistor and externally install the regenerative resistor (between RB1 and RB2 of Connector CN X2 in case of A-D-frame, between P and B2 of terminal block in case of E-F-frame).</p> <table border="1" style="width: 100%; border-collapse: collapse;"> <thead> <tr> <th>Setup value</th> <th>Regenerative resistor to be used</th> <th>Regenerative processing and regenerative resistor overload</th> </tr> </thead> <tbody> <tr> <td><0> (C, D, E and F-frame)</td> <td>Built-in resistor</td> <td>Regenerative processing circuit will be activated and regenerative resistor overload protection will be triggered according to the built-in resistor (approx. 1% duty).</td> </tr> <tr> <td>1</td> <td>External resistor</td> <td>The driver trips due to regenerative overload protection (Err18), when regenerative processing circuit is activated and its active ratio exceeds 10%,</td> </tr> <tr> <td>2</td> <td>External resistor</td> <td>Regenerative processing circuit is activated, but no regenerative over-load protection is triggered.</td> </tr> <tr> <td><3> (A, B-frame)</td> <td>No resistor</td> <td>Both regenerative processing circuit and regenerative protection are not activated, and built-in capacitor handles all regenerative power.</td> </tr> </tbody> </table> <p><Remarks> Install an external protection such as thermal fuse when you use the external regenerative resistor. Otherwise, the regenerative resistor might be heated up abnormally and result in burnout, regardless of validation or invalidation of regenerative over-load protection.</p> <p><Caution> When you use the built-in regenerative resistor, never to set up other value than 0. Don't touch the external regenerative resistor. External regenerative resistor gets very hot, and might cause burning.</p>	Setup value	Regenerative resistor to be used	Regenerative processing and regenerative resistor overload	<0> (C, D, E and F-frame)	Built-in resistor	Regenerative processing circuit will be activated and regenerative resistor overload protection will be triggered according to the built-in resistor (approx. 1% duty).	1	External resistor	The driver trips due to regenerative overload protection (Err18), when regenerative processing circuit is activated and its active ratio exceeds 10%,	2	External resistor	Regenerative processing circuit is activated, but no regenerative over-load protection is triggered.	<3> (A, B-frame)	No resistor	Both regenerative processing circuit and regenerative protection are not activated, and built-in capacitor handles all regenerative power.
Setup value	Regenerative resistor to be used	Regenerative processing and regenerative resistor overload																	
<0> (C, D, E and F-frame)	Built-in resistor	Regenerative processing circuit will be activated and regenerative resistor overload protection will be triggered according to the built-in resistor (approx. 1% duty).																	
1	External resistor	The driver trips due to regenerative overload protection (Err18), when regenerative processing circuit is activated and its active ratio exceeds 10%,																	
2	External resistor	Regenerative processing circuit is activated, but no regenerative over-load protection is triggered.																	
<3> (A, B-frame)	No resistor	Both regenerative processing circuit and regenerative protection are not activated, and built-in capacitor handles all regenerative power.																	
6D *	Detection time of main power off	35 – 1000 <35>	2ms	<p>You can set up the time to detect the shutoff while the main power is kept shut off continuously. The main power off detection is invalid when you set up this to 1000.</p>															
6E	Torque setup at emergency stop	0 – 500 <0>	%	<p>You can set up the torque limit in case of emergency stop as below.</p> <ul style="list-style-type: none"> During deceleration of over-travel inhibit with the setup 2 of Pr66 (Sequence at over-travel inhibit input) During deceleration with the setup of 8 or 9 of Pr67 (Sequence at main power off) During deceleration with the setup of 8 or 9 of Pr69 (Sequence at Servo-OFF) <p>Normal torque limit is used by setting this to 0.</p>															
70	Setup of position deviation excess	0 – 32767 <25000>	256 x resolution	<ul style="list-style-type: none"> You can set up the excess range of position deviation. Set up with the encoder pulse counts at the position control and with the external scale pulse counts at the full-closed control. Err24 (Error detection of position deviation excess) becomes invalid when you set up this to 0. 															

<Notes>

- For parameters which No. have a suffix of "*", changed contents will be validated when you turn on the control power.

Full-Closed Control Mode

Parameter Setup

Standard default : < >

PrNo.	Title	Setup range	Unit	Function/Content
72	Setup of over-load level	0 – 500 <0>	%	<ul style="list-style-type: none"> You can set up the over-load level. The overload level becomes 115 [%] by setting up this to 0. Use this with 0 setup in normal operation. Set up other value only when you need to lower the over-load level. The setup value of this parameter is limited by 115[%] of the motor rating.
73	Setup of over-speed level	0 – 20000 <0>	r/min	<ul style="list-style-type: none"> You can set up the over-speed level. The over-speed level becomes 1.2 times of the motor max. speed by setting up this to 0. Use this with 0 setup in normal operation. Set up other value only when you need to lower the over-speed level. The setup value of this parameter is limited by 1.2 times of the motor max. speed. <p><Caution> The detection error against the setup value is ±3 [r/min] in case of the 7-wire absolute encoder, and ±36 [r/min] in case of the 5-wire incremental encoder.</p>

Parameters for Full-Closed Control

Standard default : < >

PrNo.	Title	Setup range	Unit	Function/Content						
78 *	Numerator of external scale division	0 – 232767 <0>	–	<p>You can setup the ratio between the encoder resolution and the external scale resolution at full-closed control.</p> $\frac{\text{Encoder resolution per one motor revolution}}{\text{External scale resolution per one motor revolution}} = \frac{\text{Pr78} \times 2^{\text{Pr79}}}{\text{Pr7A}}$						
79 *	Multiplier of numerator of external scale division	0 – 217 <0>	–	<ul style="list-style-type: none"> Pr78= <0> (default) Numerator equals to encoder resolution, and you can setup the external scale resolution per one motor revolution with Pr7A. Pr78 ≠ 0, Setup the ratio between the external scale resolution and the encoder resolution per one motor revolution according to the above formula. 						
7A *	Denominator of external scale division	1 – 232767 <10000>	–	<p><Caution></p> <ul style="list-style-type: none"> Upper limit of numerator value after calculation is 131072. Setup exceeding this value will be invalidated, and 131702 will be the actual numerator. 						
7B *	Setup of hybrid deviation excess	1 – 210000 <100>	16 x external scale pulse	<ul style="list-style-type: none"> You can setup the permissible gap (hybrid deviation) between the present motor position and the present external scale position. The driver will trip with Err25 (Hybrid deviation excess protection) when the deviation is generated which exceeds the permissible gap. 						
7C *	Reversal of direction of external scale	0 – 21 <0>	–	<p>You can set up the logic of the absolute data of the external scale.</p> <table border="1"> <thead> <tr> <th>Setup value</th> <th>Content</th> </tr> </thead> <tbody> <tr> <td>0</td> <td>Serial data will increase when the detection head travels to the right viewed from the mounting side. (+ count)</td> </tr> <tr> <td>1</td> <td>Serial data will decrease when the detection head travels to the right viewed from the mounting side. (– count)</td> </tr> </tbody> </table> <p><Caution> When you use the linear scale by other manufacture than Mitutoyo, position data will be kept as it is with the setup of 0, and it will become as a reversed signed position data with the setup of 1.</p>	Setup value	Content	0	Serial data will increase when the detection head travels to the right viewed from the mounting side. (+ count)	1	Serial data will decrease when the detection head travels to the right viewed from the mounting side. (– count)
Setup value	Content									
0	Serial data will increase when the detection head travels to the right viewed from the mounting side. (+ count)									
1	Serial data will decrease when the detection head travels to the right viewed from the mounting side. (– count)									

<Notes>

- For parameters which No. have a suffix of "*", changed contents will be validated when you turn on the control power.

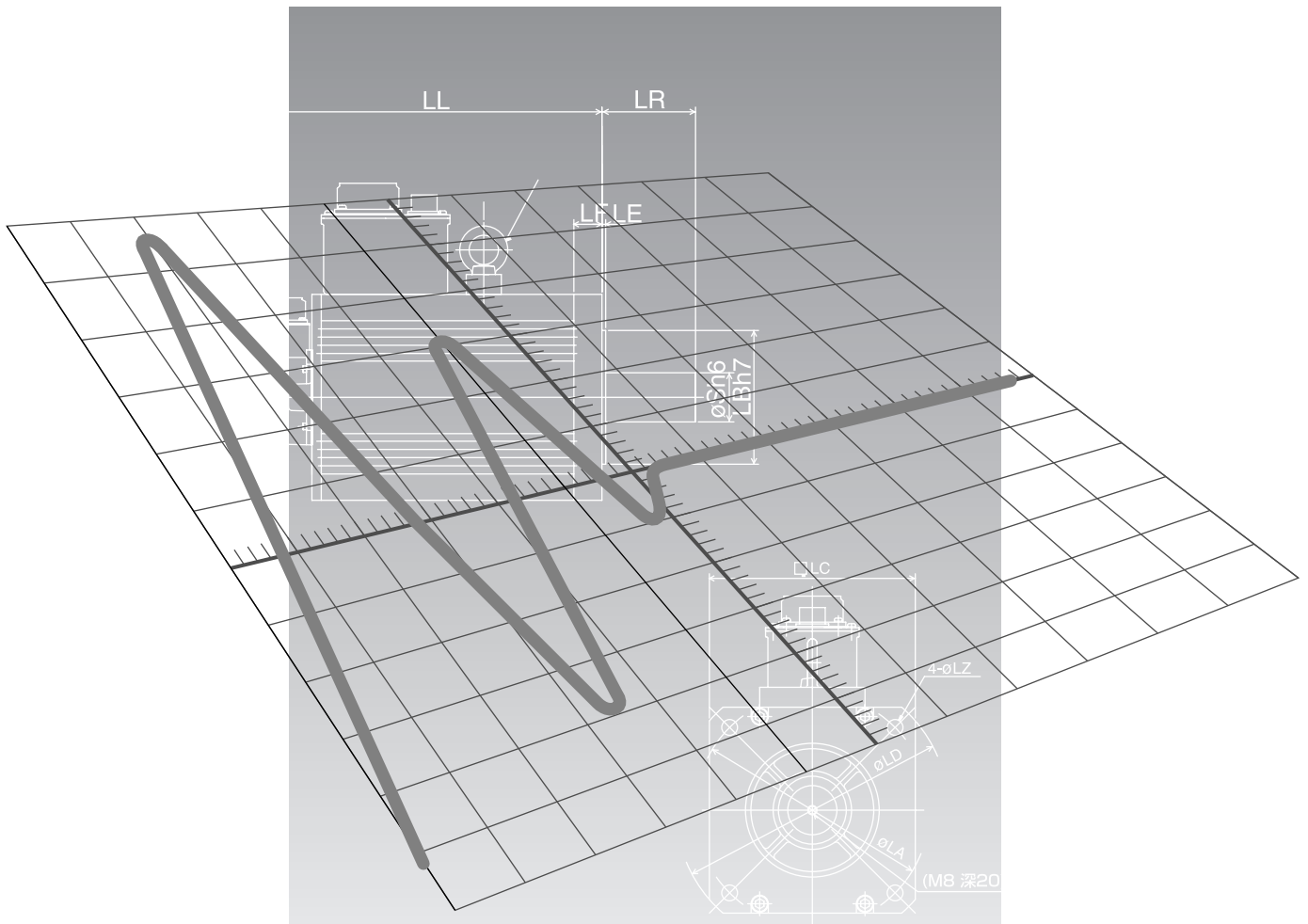

[Adjustment]

	page
Gain Adjustment	226
Real-Time Auto-Gain Tuning	228
Fit-Gain Function	231
Adaptive Filter	234
Normal Auto-Gain Tuning	236
Release of Automatic Gain Adjusting Function .	239
Manual Auto-Gain Tuning (Basic)	240
Adjustment in Position Control Mode	241
Adjustment in Velocity Control Mode	241
Adjustment in Torque Control Mode	242
Adjustment in Full-Closed Control Mode	242
Gain Switching Function.....	243
Suppression of Machine Resonance	246
Automatic Gain Setup Function	248
Manual Auto-Gain Tuning (Application)	249
Instantaneous Speed Observer	249
Damping Control	250